

SLIDING GATE
OPERATOR

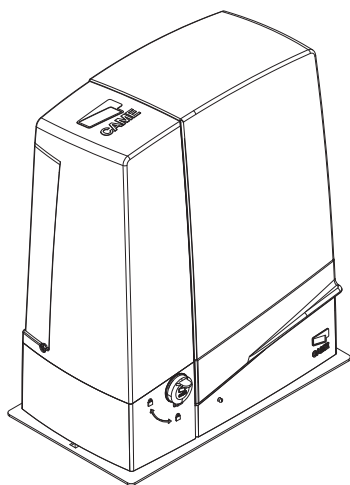

FA00014-EN



BXV

INSTALLATION MANUAL

SDN4 / SDN6 / SDN8 / SDN10

SDN4-110 / SDN6-110 / SDN8-110 / SDN10-110

EN English

CAUTION: Important safety instructions.

Follow all instructions. Improper installation may lead to serious bodily injuries. Before continuing, also read the precautions in the operating and maintenance manual.





This product must only be used for its specifically intended purpose. Any other use is dangerous. CAME S.p.A. is not liable for any damage caused by improper, wrongful and unreasonable use. • This manual's product is defined by machinery directive 2006/42/CE as "partly-completed machinery". Quasi-completed machinery is an assembly that almost constitutes a machine, but which, alone, cannot ensure a clearly defined application. Partly-completed machinery is only destined to be incorporated or assembled to other machinery or other partly-completed machinery or apparatuses to build machinery that is regulated by Directive 2006/42/CE. The final installation must be compliant with European directive 2006/42/CE and European reference standards: EN 13241-1, EN 12453, EN 12445 ed EN 12635. **Given these considerations, all procedures stated in this manual must be exclusively performed by expert, qualified staff.** • The operator cannot be used with gates fitted with pedestrian doors, unless its operation can be activated only when the pedestrian door is in safety position • Make sure that people are not entrapped between the gate's moving and fixed parts due to the gate's movement • Before installing the operator, check that the gate is in proper mechanical conditions, that it is properly balanced and that it properly closes: if any of these conditions are not met, do not continue before having met all safety requirements • Make sure that the gate is stable and that the castors function properly and are well lubricated • The guide rail must be well-fastened to the ground, entirely above the surface and free of any impediments to the gate's movement. • The rails of the upper guide must not cause any friction. • Make sure that opening and closing limiters are fitted • Make sure the operator is installed onto a sturdy surface that is protected from any impacting

shocks • Make sure that mechanical stops are already installed • If the operator is installed lower than 2.5 from the ground or from any other access level, fit any protections and signs to prevent hazardous situations • Do not fit the operator upside down or onto elements that could yield to its weight If necessary, add reinforcements to the fastening points • Do not install door or gate leaves on tilted surfaces • Check that no lawn watering devices spray the operator with water from the bottom up • Suitably section off and demarcate the entire installation site to prevent unauthorized persons from entering the area, especially minors and children • Place cautionary signs, such as the gate plate, wherever needed and in plain sight • Use proper protections to prevent mechanical hazards when people are loitering around the machinery's range of action, for example, avoid crushing hazards between the rack and pinion • The electrical cables must run through the cable glands and not touch any parts that may overheat, such as the motor, transformer, and so on • All command and control devices must be installed at least 1.85 m from the perimeter of the gate's range of action or where they cannot be reached through the gate from the outside • All switches in maintained action mode must be positioned so that the moving gates leaves, the transit areas and vehicle thru-ways are completely visible, and yet the switches must be also away from any moving parts • Unless the action is key operated, the control devices must be fitted at, at least, 1.5 m from the ground and must not be accessible to the public • Before handing over to users, check that the system is compliant with the 2006/42/CE uniformed Machinery Directive Make sure that the operator has been properly adjusted and that the safety and protection devices, and the manual release, are working

properly • Affix a permanent tag, that describes how to use the manual release mechanism, close to the mechanism • Make sure to hand over to the end user, all operating manuals for the products that make up the final machinery.

KEY

-  This symbol shows which parts to read carefully.
-  This symbol shows which parts describe safety issues
-  This symbol shows which parts to tell users about.

The measurements, unless otherwise stated, are in millimeters.

DESCRIPTION

Operator complete with control board, movement control and obstruction detection device and mechanical limit switches for sliding gates weighing up 1,000 Kg and measuring 20 m in length.

Intended use

The operator is designed to power sliding gates in residential and apartment block settings.

 Any installation and/or use other than that specified in this manual is forbidden.

Limits to use

Type	SDN4 SDN4-110	SDN6 SDN6-110	SDN8 SDN8-110	SDN10 SDN10-110
Maximum gate-leaf length (m)	14	18	20	20
Maximum gate-leaf weight (kg)	400	600	800	1000
Pinion module	4	4	4	4

Technical data

Type	SDN4 SDN4-110	SDN6 SDN6-110	SDN8 SDN8-110	SDN10 SDN10-110
Protection rating (IP)			44	
Power supply (V - 50/60 Hz)			110 / 230 AC	
Power supply motor (V)			24 DC	
Stand-by consumption (W)			5.5	
Stand-by consumption with the RGP1 (W) module			0.5	
Maximum power (W)	170	270		400
Duty cycle			HEAVY-DUTY SERVICE	
Operating temperature (°C)			-20 ÷ +55	
Thrust (N)	350	600	800	1000
Maneuvering speed (m/min)		12		11
Weight (Kg)	10	10.5	11.5	11.7

Dimensions (mm)

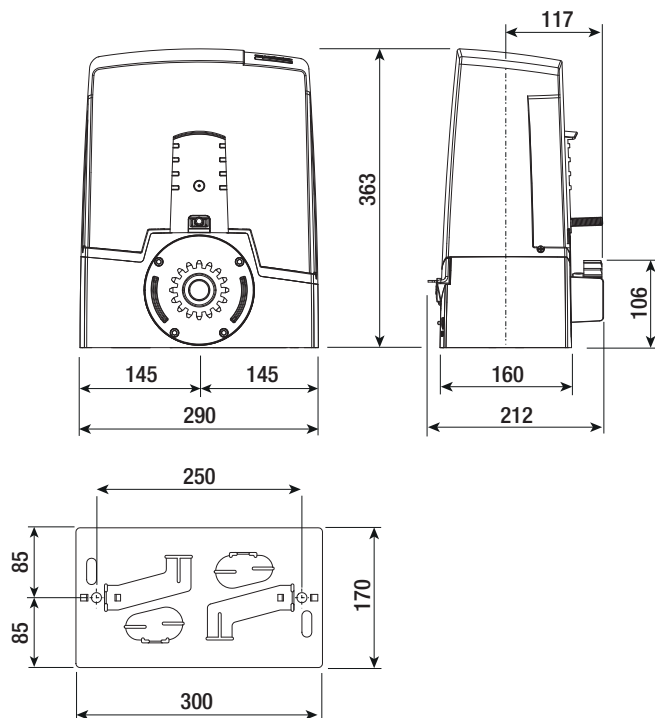

Standard installation

1. Operator
2. Limit-switch fins
3. Rack
4. Selector
5. Flashing light
6. Photocells
7. Photocell post
8. Mechanical gate stop
9. Transmitter
10. Slide guides
11. Junction pit
12. Sensitive safety-edge

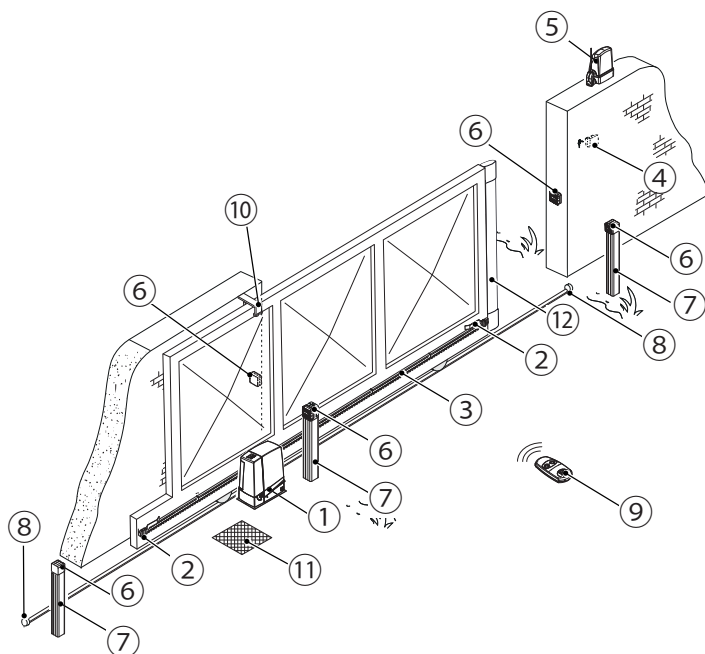

Description of parts

1. Cover
2. Board-fitting support
3. Gearmotor
4. Anchoring plate
5. Housing for two emergency batteries
6. Transformer
7. Mechanical limit switch
8. Release cable threading hole
9. Housing for the RGP1 module
10. Housing for thermostat with heating rod
11. Protection card lid
12. Control board
13. Control-board holder
14. Housing for the RLB battery charger
15. Housing for UR042 module
16. Housing for SMA and RGSM001 sensors
17. Release lever
18. Lock
19. Release key
20. Limit-switch fins

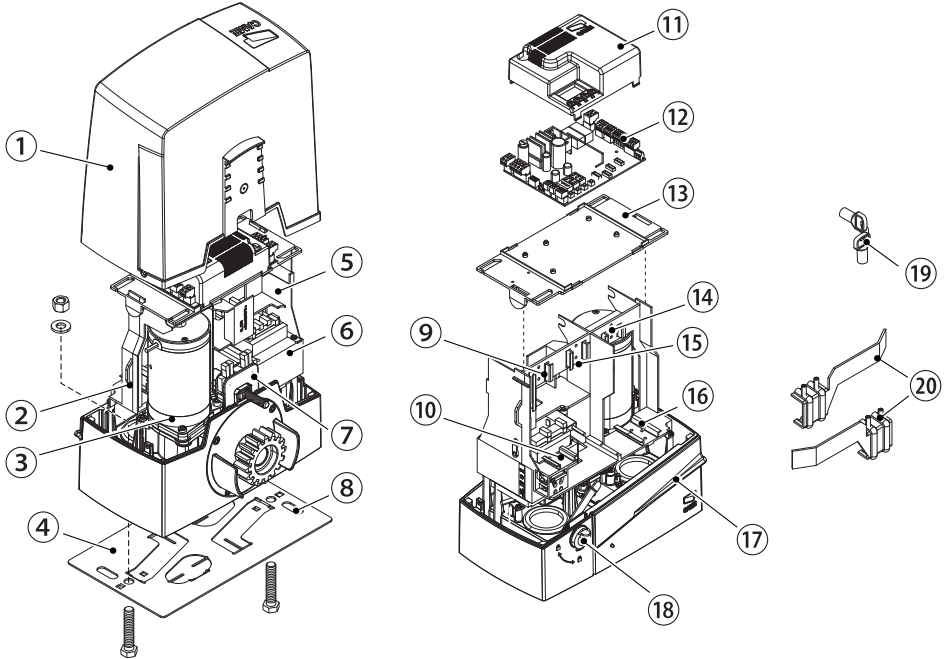

GENERAL INSTALLATION INDICATIONS

△ Only skilled, qualified staff must install this product.

Preliminary checks

△ Before beginning the installation, do the following:

- check that the gate is stable and that the casters are in good working order and lubricated;
- check that the ground rails are well-fastened, entirely on the surface and are smooth and level so as not to obstruct the gate's movement;
- check that the upper slide-guides are friction-free;
- make sure there are opening and closing mechanical gate stops;
- make sure that the point where the gearmotor is fastened is protected from any impacts and that the surface is solid enough;
- Make sure you have set up a suitable dual pole cut off device along the power supply that is compliant with the installation rules. It should completely cut off the power supply according to category III surcharge conditions (that is, with minimum contact openings of 3 mm);
- ⚠ make sure that any connections inside the container (ones that ensure continuity to the protection circuit) are fitted with additional insulation with respect to those of other electrical parts inside;
- set up suitable tubes and conduits for the electric cables to pass through, making sure they are protected from

any mechanical damage.

Tools and materials

Make sure you have all the tools and materials you will need for installing in total safety and in compliance with applicable regulations. The figure shows some of the equipment installers will need.

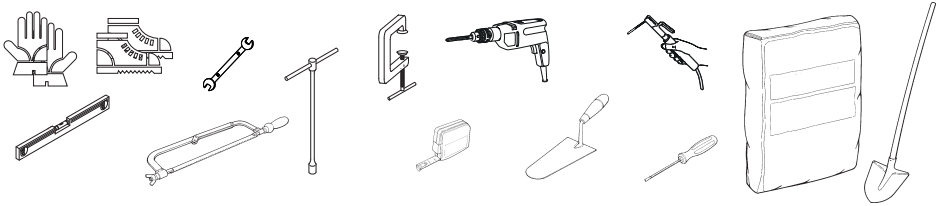

CABLE TYPES AND MINIMUM SECTIONS

Connection	cable length	
	< 20 m	20 < 30 m
Power supply for 230 V AC control board (1P+N+PE)	3G x 1.5 mm ²	3G x 2.5 mm ²
Signaling devices	2 x 0.5 mm ²	
Command and control devices	2 x 0.5 mm ²	
Safety devices (photocells)	(TX = 2 x 0.5 mm ²)	
	(RX = 2 x 0.5 mm ²)	

📖 When operating at 230 V and outdoors, use H05RN-F-type cables that are 60245 IEC 57 (IEC) compliant; whereas indoors, use H05VV-F-type cables that are 60227 IEC 53 (IEC) compliant. For power supplies up to 48 V, you can use FROR 20-22 II-type cables that comply with EN 50267-2-1 (CEI).

📖 To connect the antenna, use the RG58 (we suggest up to 5 m).

📖 For paired connection and CRP, use a UTP CAT5-type cable (up to 1,000 m long).

📖 If cable lengths differ from those specified in the table, establish the cable sections depending on the actual power draw of the connected devices and according to the provisions of regulation CEI EN 60204-1.

📖 For multiple, sequential loads along the same line, the dimensions on the table need to be recalculated according to the actual power draw and distances. For connecting products that are not contemplated in this manual, see the literature accompanying said products

INSTALLING

△The following illustrations are mere examples. Consider that the space available where to fit the barrier and accessories will vary depending on the area where it is installed. It is up to the installer to find the most suitable solution.

Corrugated tube laying

Dig a hole for the foundation frame.

Set up the corrugated tubes needed for making the connections coming out of the junction pit.

For connecting the gearmotor we suggest using a \varnothing 40 mm corrugated tube, whereas for the accessories we suggest \varnothing 25 mm tubes.

Set up a \varnothing 20 mm tube for running through the external release cable **A**.

📖 The number of tubes depends on the type of system and the accessories you are going to fit.

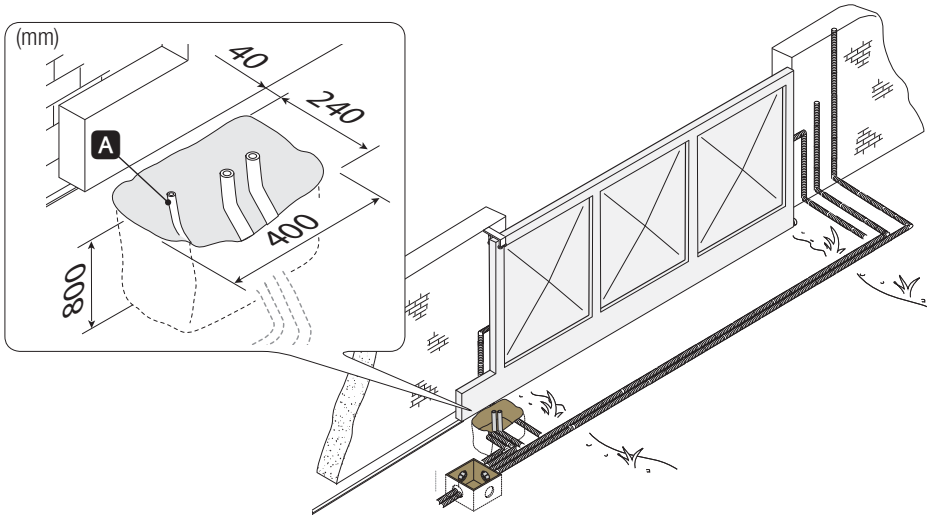

Laying the anchoring plate

Set up a foundation frame that is larger than the anchoring plate and sink it into the dug hole. The foundation frame must jut out by 50 mm above ground level.

Fit an iron cage into the foundation frame to reinforce the concrete.

Fit the bolts into the anchoring plate and lock them using the washers and nuts. Remove the pre-shaped clamps using a screw driver or pliers.

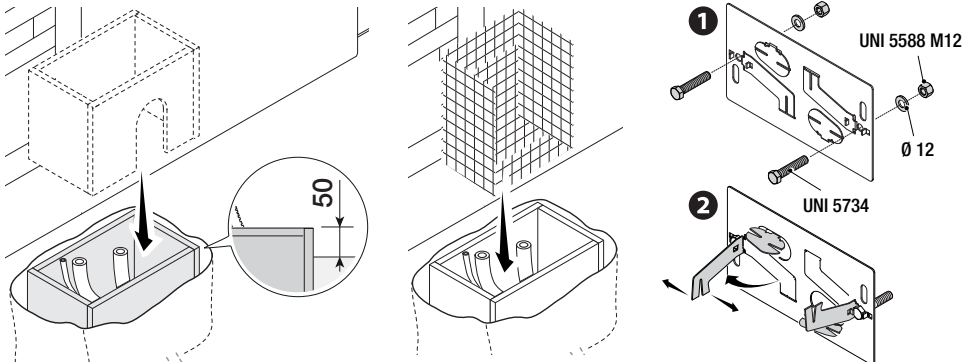

If the rack is already there, place the anchoring plate, being careful to respect the measurements shown in the drawing.

Careful! The tubes must pass through their corresponding holes.

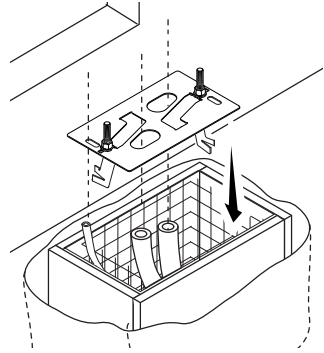
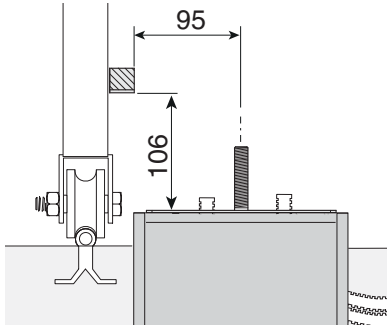

Fill the foundation frame with concrete. The plate must be perfectly level with the bolts which are entirely above surface.

Wait at least 24 hrs for the concrete to solidify.

Remove the foundation frame and fill the hole with earth around the concrete block.

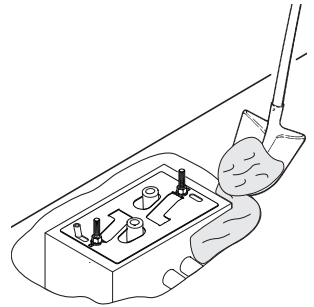
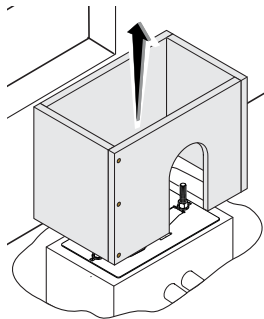
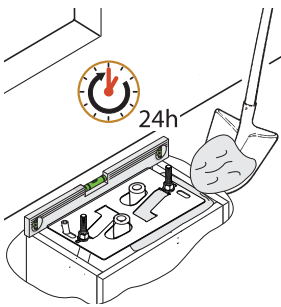

Remove the nut and washer from the bolts

Fit the electric cables into the tubes so that they come out about 600 mm.

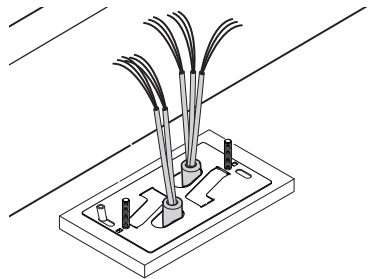
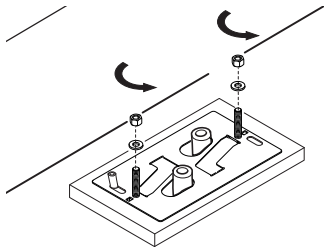

Setting up the gearmotor

Remove the gearmotor cover by loosening the side screws.

Place the gearmotor above the anchoring plate.

Careful! The electric cables must pass under the gearmotor case.

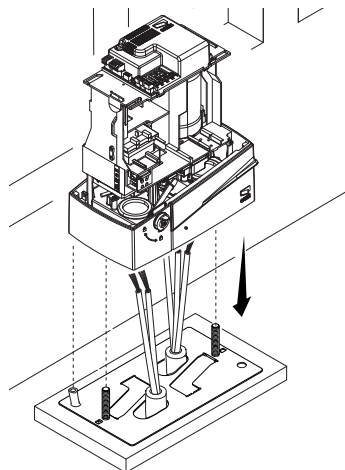
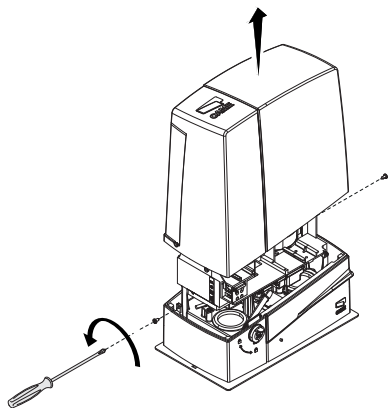

Perforate the cable gland, pass the cables through and fit it into its corresponding housing.

Raise the gearmotor by 5 to 10 mm from the plate by turning the threaded feet, to make room for further pinion and rack adjustments.

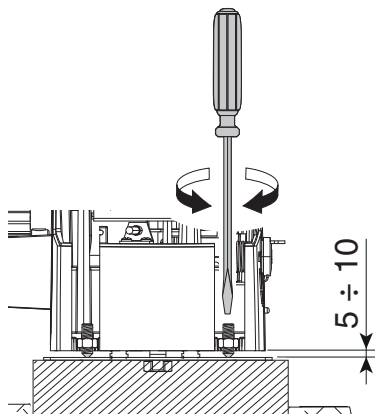
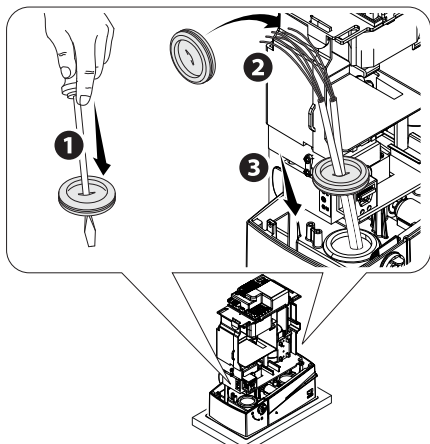

Fastening the rack

If the rack is already set up, the next step should be to adjust the rack-and-pinion coupling distance, otherwise, fasten it:

- release the gearmotor (see **RELEASING THE GEARMOTOR** paragraph);
- rest the rack above the gearmotor pinion;
- weld or fasten the rack to the gate along its entire length.

To assemble the rack modules, use an extra piece and rest it under the joint, then fasten it using two clamps.

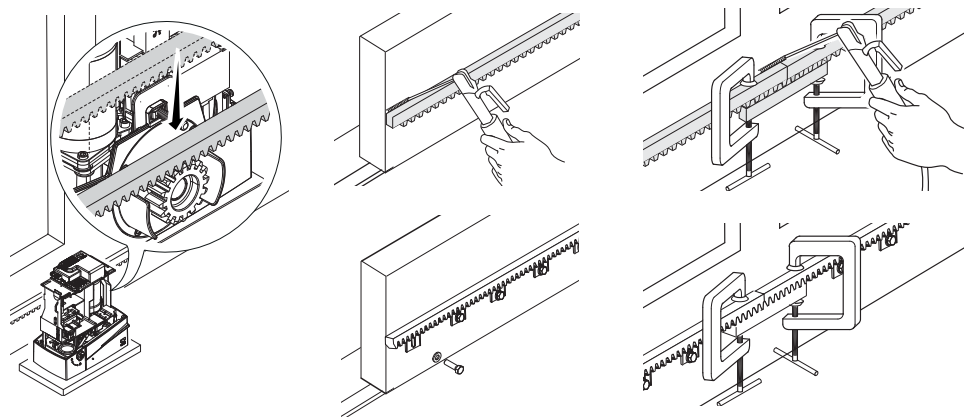

Adjusting the pinion-rack coupling

Manually open and close the gate and adjust the pinion-rack coupling distance using the threaded feet (vertical adjustment) and the holes (horizontal adjustment). This prevents the gate's weight from bearing down on the operator.

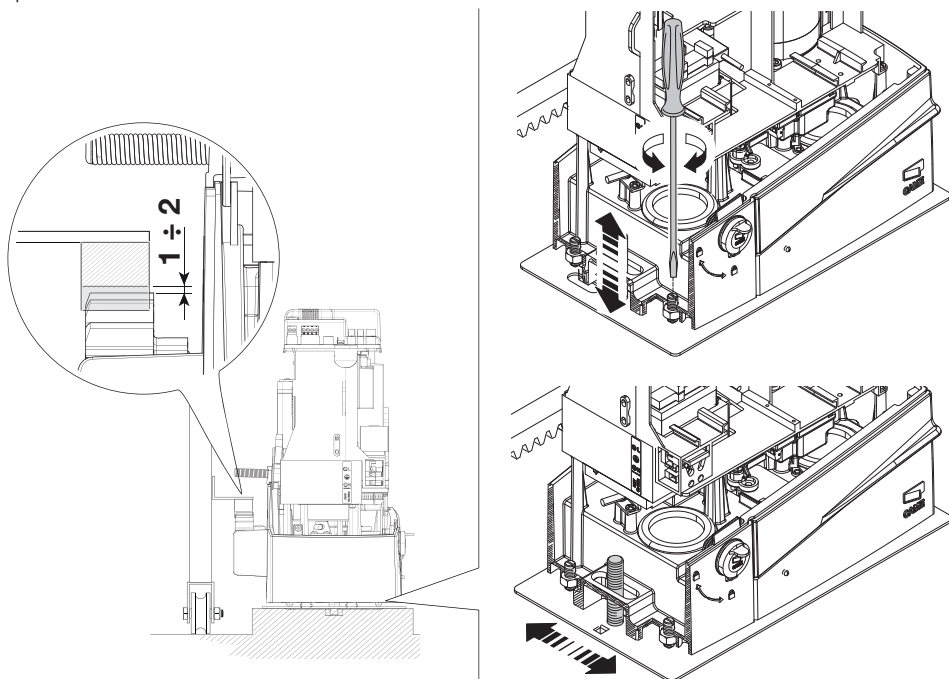

Fastening the gearmotor

Complete the adjusting, fasten the gearmotor to the plate using the washers and nuts.

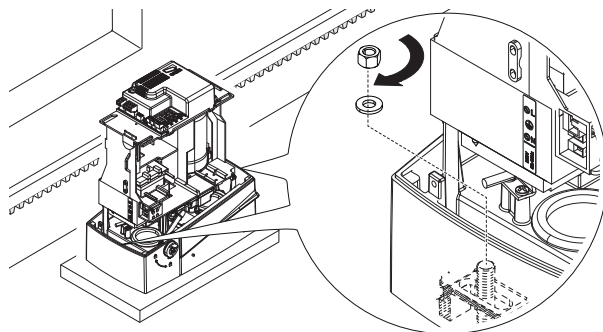

Establishing the limit-switch points

For opening:

- open the gate **1**;
- fit the opening limit-switch fin onto the rack until the micro switch activates (spring) and fasten it using the grub screws **2 3**.

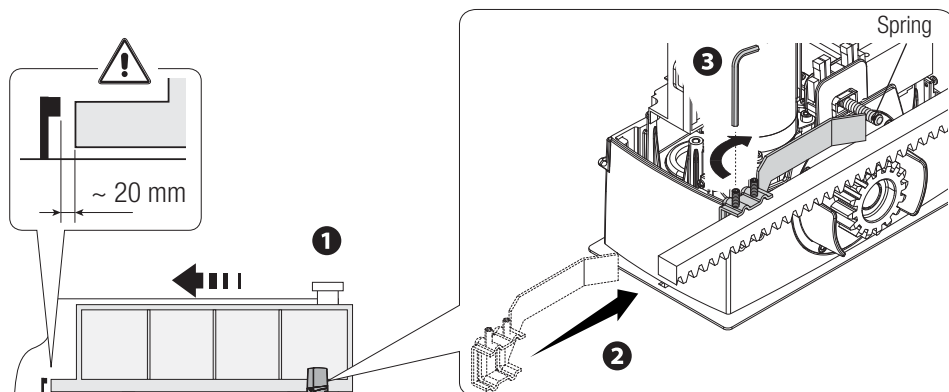

For closing:

- close the gate **4**;
- fit the closing limit-switch fin into the rack until the micro-switch is activated (spring) and fasten it using the grub screws **5 6**.

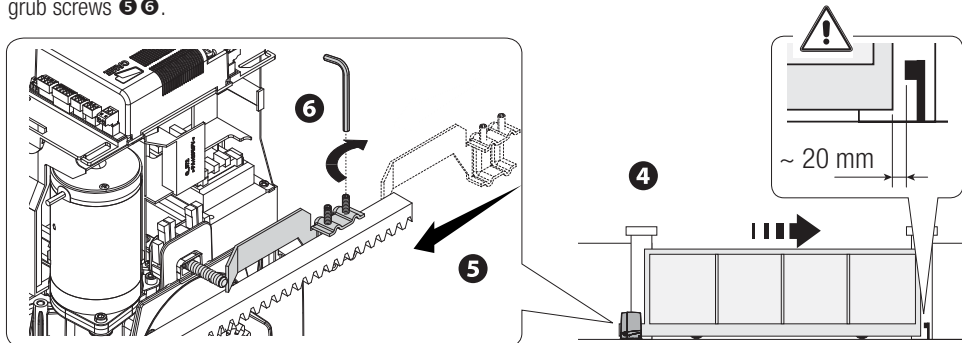

ELECTRICAL CONNECTIONS AND PROGRAMMING

⚠Warning! Before working on the control panel, cut off the main current supply and, if present, remove any batteries.

Power supply to the control board and control devices : 24 V AC/ DC.

Functions on the input and output contacts, time adjustments and user-management settings are set and viewed on the control board's display.

All connections are quick-fuse protected.

Fuses	ZN7
LINE - Line	1.6 A-F (230 V) / 3.15 A-F (110 V)
ACCESSORIES - Accessories	2 A-F

Description of parts

1. Terminal for gearmotors
2. Terminals for encoders
3. Terminals for limit-switches
4. Command and safety devices terminals
5. Antenna terminal
6. AF card connector
7. Memory Roll card connector
8. R700/R800 board connector
9. RSE board connector
10. Connector for the RIO-CONN card
11. Display
12. Programming buttons
13. Terminals for paired of CRP connection
14. Terminal board for keypad devices
15. Terminal board for transponder selector
16. Connector for the GSM module
17. Terminals for the RGP1 module
18. Terminals for signaling devices
19. Accessories fuse
20. Terminals for powering the control board
21. Line fuse
22. Power supply terminal board

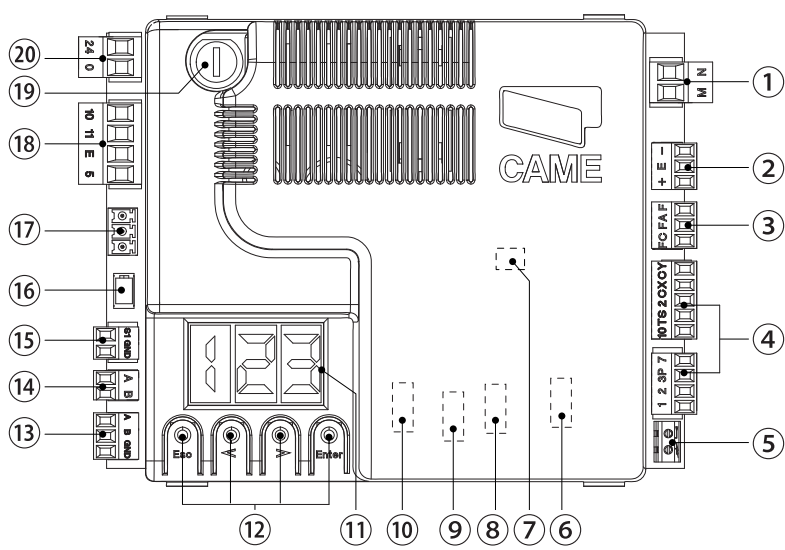
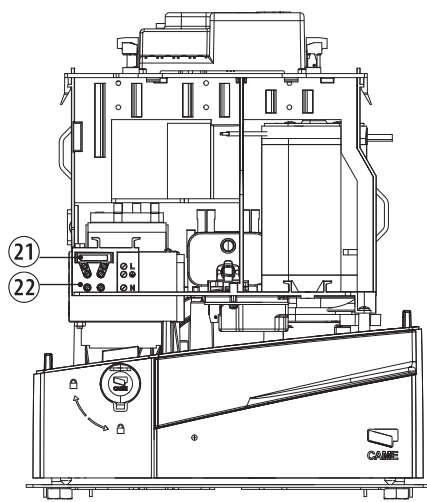

Power supply

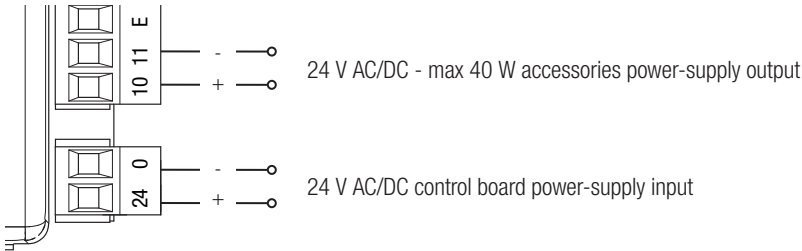
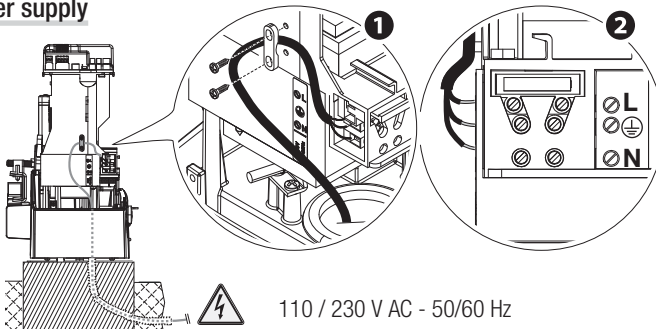

Factory wiring

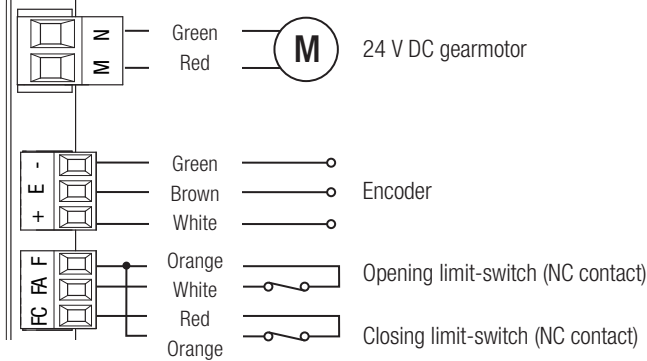

Signaling devices

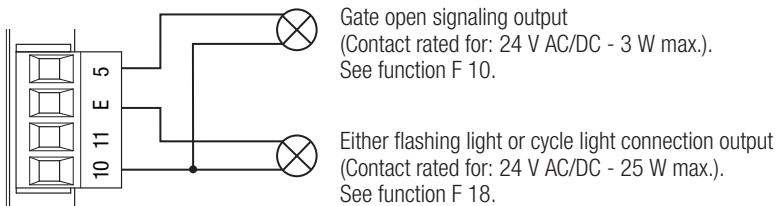

Command and control devices

WARNING! For the system to work properly, before fitting any plug-in card, such as the AF or R800 one, you **MUST CUT OFF THE MAINS POWER SUPPLY** and, if present, disconnect any batteries.

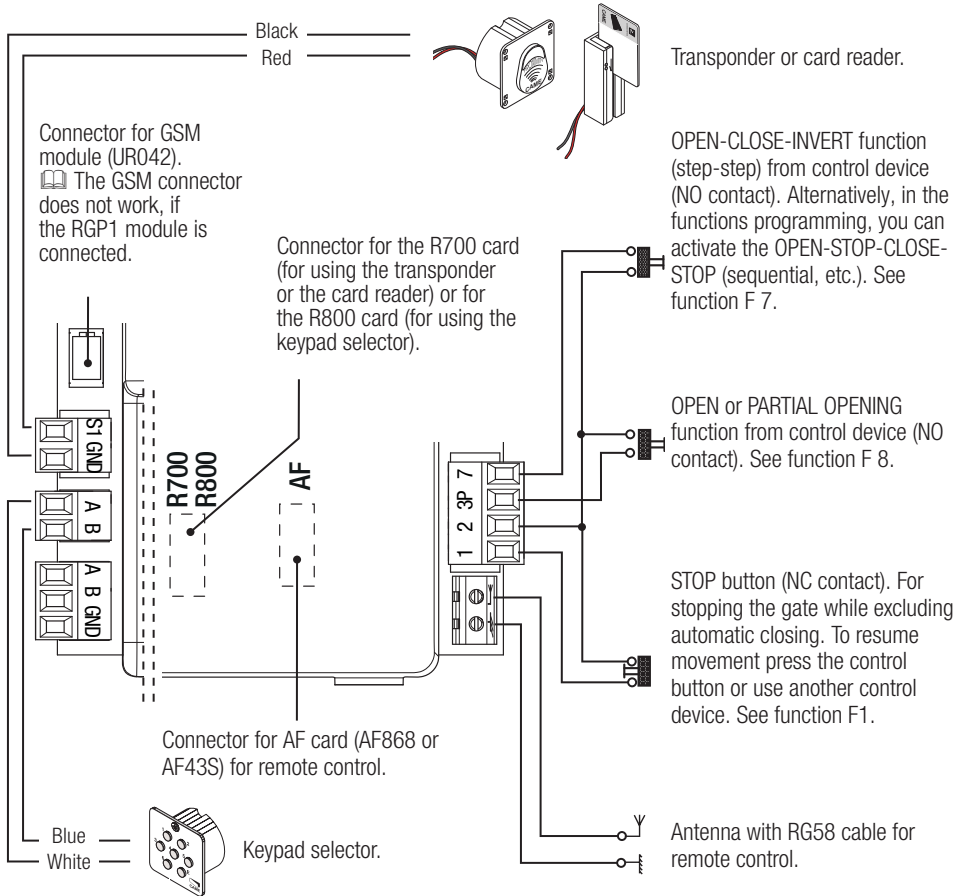

To be able to snap in the cards into the dedicated connectors, remove the card cover.

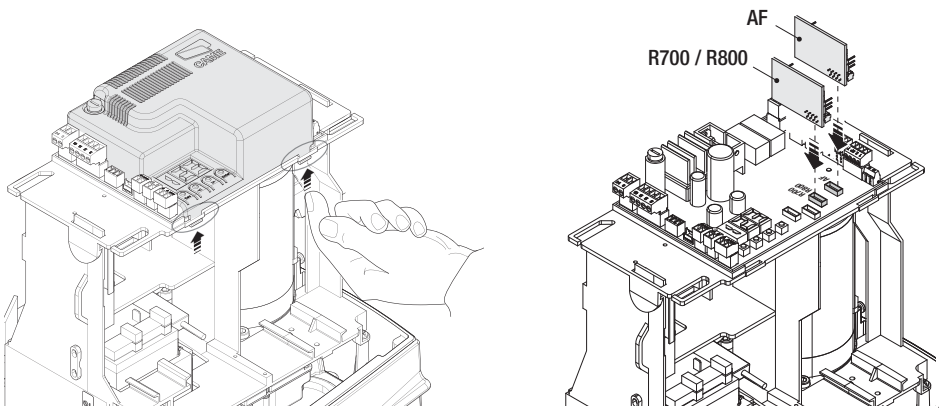

Safety devices

Photocells

Configure contact CX or CY (NC), input for safety devices such as photocells, which comply with EN 12978 regulations.

See CX input functions (Function F2) or CY (Function F3) in:

- C1 reopening during closing. When the gate is closing, opening the contact triggers the inversion of movement until the gate is fully open again;
- C2 close back up during opening. When the gate is opening, opening the contact triggers the inversion of movement until the gate is completely closed.
- C3 partial stop. Stopping of the gate, if it is moving, with consequent automatic closing (if the automatic closing function has been entered);
- C4 obstruction wait. Stopping of the gate, if it is moving, which resumes movement once the obstruction is removed.

 If contacts CX and CY are not used they should be deactivated during programming.

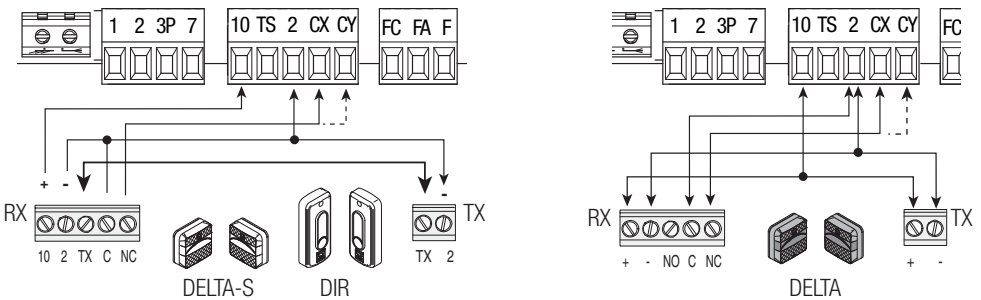

Sensitive Safety Edges

Configure contact CX or CY (NC), input for safety devices such as sensitive safety-edges, that are EN 12978 regulation compliant.

See CX input functions (Function F2) or CY (Function F3) in:

- C7 reopening during closing. When the gate is closing, opening the contact triggers the inversion of movement until the gate is fully open again;
- C8 reclosing during opening. When the gate is opening, opening the contact triggers the inversion of movement until the gate is fully closed.

 If contacts CX and CY are not used they should be deactivated during programming.

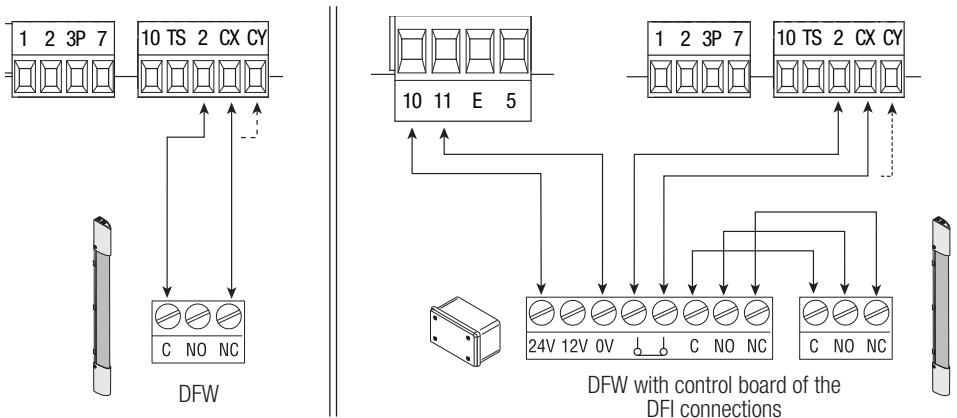

Connecting the safety devices (i.e. the safety test)

At each opening and closing command, the control board checks the efficacy of the safety devices (such as, photocells).

Any malfunction inhibits any command and is signaled on display E4.

Enable function F5 in programming.

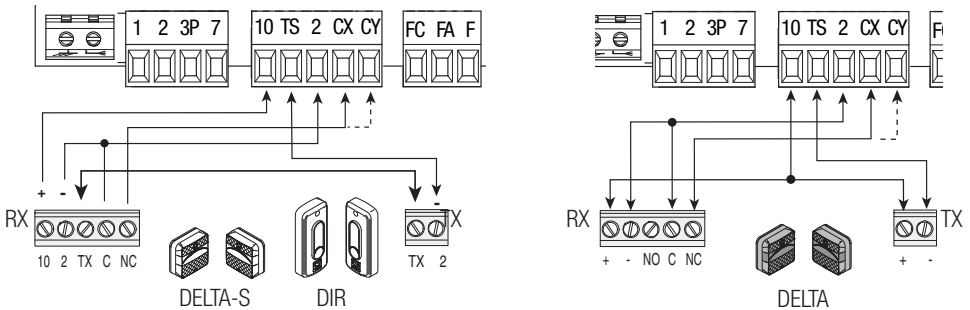

Rio Wireless devices

Fit the RIO-CONN card into the corresponding connector on the control board.

Set the function to be associated to the wireless device (F65, F66, F67 e F68).

Configure the RIO-EDGE, RIO-CELL and RIO-LUX wireless devices by following the indications shown in the folder enclosed with each accessory.

📖 If the devices are not configured with the RIO-CONN card, the E18 error message appears on the display.

⚠️ If there are any radio-frequency disturbances to the system, the wireless system will inhibit the normal operation of the operator, and this error will show up on the display as E17.

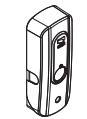
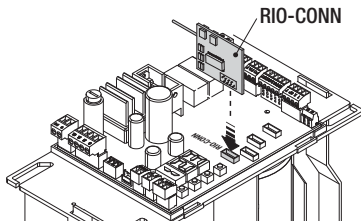

RIO-EDGE

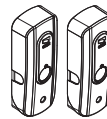

RIO-CELL

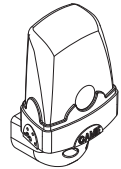

RIO-LUX

Connection for paired operation and for CRP (Came Remote Protocol)

See the PAIRED CONNECTION WITH SINGLE CONTROL chapter.

Fit the RSE card.

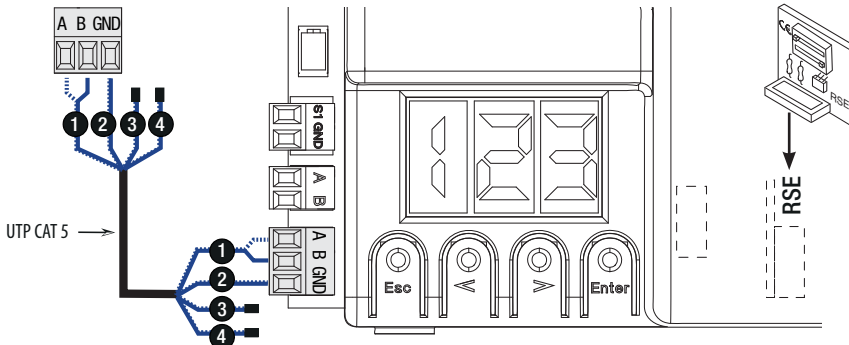

Description of programming commands

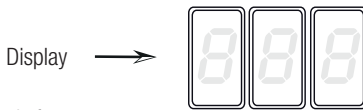

The ESC button is for:

- exiting menus;
- cancelling changes.
- during operation it works from a STOP command

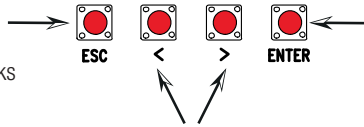

The ENTER key is for:

- entering menus;
- confirming or memorizing set values.

The < > keys are for:

- moving from one item to another;
- increasing or decreasing values.
- after a travel calibration they allow an OPEN or CLOSE command

Browsing the menu

To enter the menu, keep the ENTER button pressed for at least one second.

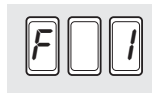

To select menu items, use the arrow keys ...

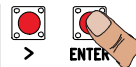
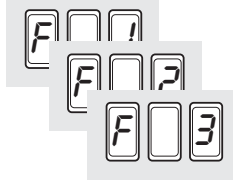
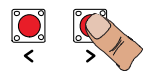

... then press ENTER

also for the submenus, use the arrow keys to select ...

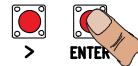
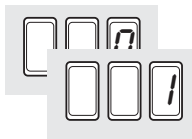
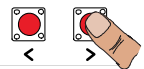

... then press ENTER

To increase or decrease a value, use the arrow keys ...

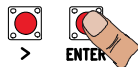
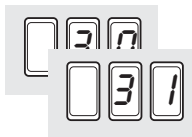
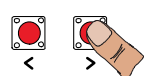

... the press ENTER to confirm ...

... to exit the menu, wait 10 seconds or press ESC.

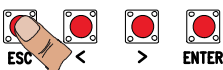

📖 When the menu is active, the system cannot be used.

Functions map

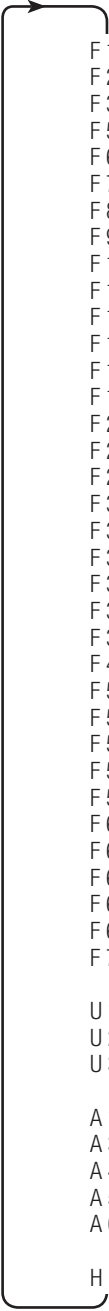
- 
- F 1 Total stop function (1-2)
 - F 2 Function associated to input 2-CX
 - F 3 Function associated to input 2-CY
 - F 5 Safety test function
 - F 6 Maintained action function
 - F 7 Control mode on 2-7
 - F 8 Control mode on 2-3P
 - F 9 Obstruction detection with motor idle function
 - F 10 Function associated to the gate-open signaling output
 - F 11 Encoder exclusion
 - F 12 Slowed-down start function
 - F 14 Sensor type selection function
 - F 18 Additional light function
 - F 19 Automatic closing time
 - F 20 Automatic closing time after partial opening
 - F 21 Preflashing time
 - F 28 Adjusting opening speed
 - F 30 Adjusting opening slow-down speed
 - F 34 Sensitivity during movement
 - F 35 Sensitivity during slow-down
 - F 36 Adjusting partial opening
 - F 37 Adjusting the gearmotor's opening slow-down starting point
 - F 38 Adjusting the gearmotor's closing slow-down starting point
 - F 49 Managing the serial connection
 - F 50 Saving data in memory roll
 - F 51 Reading memory roll data
 - F 52 Transferring parameters from Master to Slave
 - F 54 Opening direction
 - F 56 Peripheral number
 - F 63 Changing COM speed
 - F 65 Function associated to the RIO-EDGE [T1] input
 - F 66 Function associated to the RIO-EDGE [T2] input
 - F 67 Function associated to the RIO-CELL [T1] input
 - F 68 Function associated to the RIO-CELL [T2] input
 - F 71 Partial opening time

 - U 1 Entering new user with an associated command
 - U 2 Deleting single users
 - U 3 Deleting all users

 - A 1 Motor-type setting
 - A 3 Travel calibration
 - A 4 Resetting parameters
 - A 5 Counting maneuvers
 - A 6 Adjusting the motor torque



 - H 1 Software version



Functions menu







 **IMPORTANT! Start programming by first performing the following: MOTOR-TYPE SETTING (A1), OPENING DIRECTION (F54), TOTAL STOP (F1) and TRAVEL CALIBRATION (A3)**



 **Programming the features is to be done when the operator is stopped.**

 **You can memorize up to 25 maximum users.**

F1 Total stop [1-2]	OFF = Deactivated (default) / ON = Activated
NC input – Gate stop that excludes any automatic closing; to resume movement, use the control device. The safety device is inserted into [1-2].	
F2 Input [2-CX]	OFF = Deactivated (default) / C1 / C2 / C3 / C4 / C7 / C8
NC input – Can associate: C1 = reopening during closing by photocells, C2 = reclosing during opening by photocells, C3 = partial stop, C4 = obstruction wait, C7 = reopening during closing by sensitive safety-edges, C8 = reclosing during opening by sensitive safety-edges.	
F3 Input [2-CY]	OFF = Deactivated (default) / C1 / C2 / C3 / C4 / C7 / C8
NC input – Can associate: C1 = reopening during closing by photocells, C2 = reclosing during opening by photocells, C3 = partial stop, C4 = obstruction wait, C7 = reopening during closing by sensitive safety-edges, C8 = reclosing during opening by sensitive safety-edges.	
F5 Safety test	0 = Deactivated (default) / 1 = CX / 2 = CY / 4 = CX+CY
After every opening or closing command, the board will check whether the photocells are working properly.  The safety test is always active for wireless devices.	
F6 Maintained action	OFF = Deactivated (default) / ON = Activated
The gate opens and closes by keeping the button pressed. Opening button on contact 2-3P and closing button on contact 2-7. All other control devices, even radio-based ones, are excluded.	
F7 Command [2-7]	0 = Step-step (default) / 1 = Sequential / 2 = Open / 3 = Close
From the control device connected to 2-7, it performs the (open-close-invert) step-step, (open-stop-close-stop), sequential, open or close command.	
F8 Command [2-3P]	1 = Partial opening / 2 = Open
From the control device connected to 2-3P, it performs a partial (1) or total opening (2) of the gate.  The partial opening time is adjusted on function F 71.	
F9 Obstruction detection with motor idle	OFF = Deactivated (default) / ON = Activated
With the gate closed, opened or totally stopped, the gearmotor stays idle if the safety devices, that is, photocells or sensitive safety-edges detect an obstruction.	
F10 Gate-open signal output	0 = lit when gate is open or moving (default) / 1 = when opening it flashes intermittently every half-second, when closing it flashes intermittently every second, stays lit when gate is open is off when gate is closed
It signals the gate status. The signal device is connected to contact 10-5.	
F11 Encoder	OFF = Deactivated / ON = Activated (default)
Managing slow-downs, obstruction detections and sensitivity.	

F12 Slowed-down departure	OFF = Deactivated (default) / ON = Activated
With each opening and closing command, the gate starts moving slowly for a few seconds.	
F14 Sensor type selection	0 = command with transponder sensor or magnetic card reader / 1 = command with keypad selector (default).
Setting the type of accessory for controlling the operator.	
F18 Additional light	0 = Flashing light (default) / 1 = Cycle
Output on contact 10-E. Flashing light: it flashes during the gate's opening and closing phases. Cycle: outdoor lamp for extra lighting in the driveway. It stays lit from when the gate starts opening to when it closes, including the waiting time prior to automatic closing (only with with TCA activated).	
F19 Automatic closing time	OFF = Deactivated (default) / 1 = 1 second / ... / 180 = 180 seconds
The automatic-closing wait starts when the opening limit switch point is reached and can be set to between 1 and 180 seconds. The automatic closing does not activate if any of the safety devices trigger when an obstruction is detected, or after a total stop, or during a power outage.	
F20 Automatic closing time after a partial opening	OFF = Deactivated / 1 = 1 second / ... / 10 = seconds (default) / ... / 180 = 180 seconds
The wait before the automatic closing starts after a partial opening command for an adjustable time of between 1 s and 180 s. The automatic closing does not activate if any of the safety devices trigger when an obstruction is detected, or after a total stop, or during a power outage.  The F19 function must not be activated.	
F21 Preflashing time	OFF = Deactivated (default) / 1 = 1 second / ... / 10 = 10 seconds
Adjusting the pre-flashing time for the flashing light connected to 10-E before each maneuver. The flashing time is adjustable from one to ten seconds.	
F28 Travel speed	60 = Minimum speed / ... / 100 = Maximum speed (default)
Setting the gate's opening and closing speeds, calculated as a percentage.	
F30 Slow-down speed	10 = Minimum speed / ... / 50 = Maximum speed (default)
Setting the gate's opening and closing slow-down speed, calculated as a percentage.	
F34 Boom travel sensitivity	10 = maximum sensitivity / ... / 100 = minimum sensitivity (default)
Adjusting obstruction detection sensitivity during boom travel.	
F35 Slow-down sensitivity	10 = maximum sensitivity / ... / 100 = minimum sensitivity (default)
Adjusting obstruction detection sensitivity during slow-down.	
F36 Adjusting partial opening	10 = 10% of the gate travel (default) / ... / 80 = 80% of the gate travel
Adjustment as a percentage of total travel, during gate opening.  This function appears only if the Encoder function is activated.	

F37 Opening slow-down point	10 = 10% of the travel / ... / 25 = 25% of the travel (default) / ... / 60 = 60% of the travel
Percentage adjustment of the total gate travel, of the opening slow-down starting point.  This function appears only if the Encoder function is activated.	
F38 Closing slow-down point	10 = 10% of the travel / ... / 25 = 25% of the travel (default) / ... / 60 = 60% of the travel
Percentage adjustment of the total gate travel, from the closing slow-down starting point.  This function appears only if the Encoder function is activated.	
F49 Managing serial connection	OFF = Deactivated (default) / 1 = Paired / 3 = CRP
To enable paired operation or the Came Remote Protocol.	
F50 Save data	OFF = Deactivated (default) / ON = Activated
Saving users and saved settings in memory roll.  This feature only appears if a memory roll has been fitted into the control board.	
F51 Read data	OFF = Deactivated (default) / ON = Activated
Uploading data saved in memory roll.  This feature only appears if a memory roll has been fitted into the control board.	
F52 Passing parameter in paired mode	OFF = Deactivated (default) / ON = Activated
Uploading settings from Master to Slave.  This appears only if function F49 is set to Paired.	
F54 Opening direction	OFF = Opens left (default) / ON = Opens right
For setting the gate opening direction.	
F56 Peripheral number	1 ----> 255
To set the peripheral's number from 1 to 255 for each control board when you have a system with several operators.	
F63 Change COM speed	0 = 1200 Baud / 1 = 2400 Baud / 2 = 4800 Baud / 3 = 9600 Baud / 4 = 14400 Baud / 5 = 19200 Baud / 6 = 38400 Baud (default) / 7 = 57600 Baud / 8 = 115200 Baud
For setting the communication speed used in the CRP (Came Remote Protocol) connection system.	
F65 Wireless input RIO-EDGE [T1]	OFF = Deactivated (default) / P7 / P8
Wireless (RIO-EDGE) safety device associated to a function chosen among those available: P0 = TOTAL STOP, P7 = reopening during closing, P8 = reclosing during opening. For programming, see the instructions that come with the accessory.  This function only appears if the control board has been fitted with a RIO-CONN card.	
F66 Wireless input RIO-EDGE [T2]	OFF = Deactivated (default) / P7 / P8
Wireless (RIO-EDGE) safety device associated to a function chosen among those available: P0 = TOTAL STOP, P7 = reopening during closing, P8 = reclosing during opening. For programming, see the instructions that come with the accessory.  This function only appears if the control board has been fitted with a RIO-CONN card.	

F67 Wireless input RIO-CELL	OFF = Deactivated / P1 (default) / P2 / P3 / P4
[T1]	
RIO-CELL is associated to any function chosen among those available: P1 = reopening during closing; P2 = reclosing during opening; P3 = partial stop; P4 = obstruction wait. For programming, see the instructions that come with the accessory.  This function only appears is the control board has been fitted with a RIO-CONN card.	
F68 Wireless input RIO-CELL	OFF = Deactivated / P1 (default) / P2 / P3 / P4
[T2]	
RIO-CELL is associated to any function chosen among those available: P1 = reopening during closing; P2 = reclosing during opening; P3 = partial stop; P4 = obstruction wait. For programming, see the instructions that come with the accessory.  This function only appears is the control board has been fitted with a RIO-CONN card.	
F71 Partial opening time	5 = 5 seconds / / 40 = 40 seconds
After an opening command from the button connected to 2-3P, the gate opens for an adjustable time of between five seconds and 40 seconds.  This function only appears if the Encoder function is deactivated.	
U 1 Entering a user	1 = Step-step command (open-close) / 2 = Sequential command (open-stop-close-stop) / 3 = Only open command / 4 = Partial command
Entering up to 250 users and associating to each one a function of choice among those included. This must be done via transmitter or other control device (see "ENTERING USERS WITH ASSOCIATED COMMAND paragraph).	
U 2 Deleting a user	OFF = Disable / on = Activated
Deleting a single user	
U 3 Deleting users	OFF = Deactivated / ON = Delete all users
Deleting all users.	
A 1 Motor type	1 = 400 Kg / 2 = 600 Kg / 3 = 800 Kg / 4 = 1000 Kg
To set the gearmotor depending on the gate's weight.	
A 3 Travel calibration	OFF = Disable / on = Activated
Automatic calibration of the gate-leaf run (see the TRAVEL CALIBRATION paragraph).	
A 4 Resetting parameters	OFF = Disable / on = Activated
Warning! The default settings are restored and the travel calibration deleted.	
A 5 Counting maneuvers	0 = Number or maneuvers executed
For viewing the number of maneuvers made (001 = 100 maneuvers; 010 = 1,000 maneuvers; 100 = 10,000 maneuvers; 999 = 99,900 maneuvers; CSI = maintenance job).	
A 6 Adjusting the motor torque	1 / 2 / 3 / 4 / 5
For adjusting the motor torque from 1 (minimum) to 5 (maximum).	
H 1 Version	
View the firmware version.	

When adding and deleting users, the flashing numbers appearing are those numbers that are available and usable to assign to a new user (max. 250 users).

Entering a user with an associated command

Select U 1
Press ENTER to confirm.

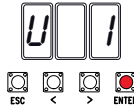

Select a command to associate to the user.
The commands are:
- step-step (open-close) = 1;
- sequential (open-stop-close-stop) = 2;
- open = 3;
- partial opening = 4.
Press ENTER to confirm...

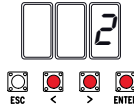

... a number between 1 and 250 will start flashing for a few seconds.
Send the code from the transmitter or other control device, such as, a keypad selector or a transponder.
Associate the number to the added user.

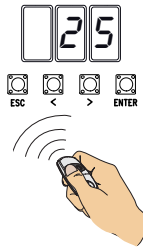

User	Associated command
1 -	
2 -	
3 -	
4 -	
5 -	
6 -	
7 -	
8 -	
9 -	
10 -	
11 -	
12 -	
13 -	
14 -	
15 -	
16 -	
17 -	
18 -	
19 -	
20 -	
21 -	
22 -	
23 -	
24 -	
25 -	

Deleting a single user

Select U 2. Press ENTER.
Activate the function and press ENTER to confirm

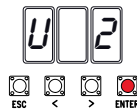

Use the arrow keys select the number of the user you wish to delete.
Press ENTER to confirm...

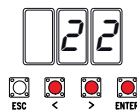

... Clr will appear on the screen to confirm deletion.

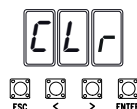

Travel calibration

📖 Before calibrating the gate travel, position the gate half-way, check that the maneuvering area is clear of any obstruction and check that there are mechanical opening and closing stops.

⚠️ The mechanical end-stops are obligatory.

Important! When calibrating, all safety devices will be disabled excluding the one for TOTAL STOP which is active on the ESC button.

Select A 3.

Press ENTER to confirm.

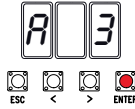

Select 1 and press ENTER to confirm the travel calibration operation.

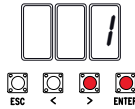

The gate will perform a closing maneuver until it reaches a final stop...

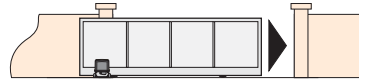
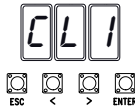

...then the gate will perform an opening maneuver until it reaches a final stop.

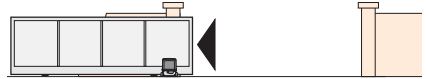
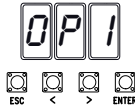

Memory Roll Card

To memorize user data and configure the system, to then reuse them with another control board even on another system.

📖 After memorizing the data, it is best to remove the memory roll.

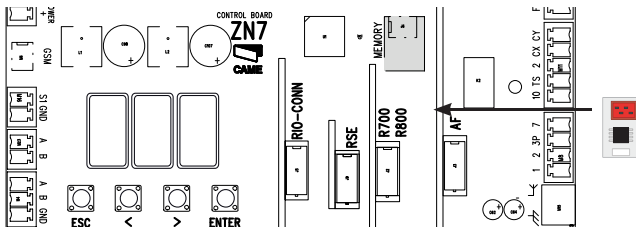

PAIRED CONNECTION

 Important! Start by performing the following procedures on both operators:

- fit the RSE card (with the DIP-switches set to OFF) on the connector of both operator's cards.
- connect the two circuit cards with a CAT 5-type cable (max. 1,000 m) onto terminals A-A / B-B / GND-GND.
- connect all of the control and safety devices on the MASTER operator's control panel.

 Important! All functions settings must be done on the MASTER control panel.

Configuring the MASTER operator

Select function F 49. Press ENTER to confirm.

Select 1 (paired) and press ENTER.

Perform settings and adjustments on the control board.

Transferring parameters from MASTER to SLAVE

Select function F 52 on the MASTER control panel.

Select 1 and press ENTER.

Programming

On both operators, set the following functions:

- the type of motor (A1);
- the opening direction (F54);
- total stop (F1);
- travel calibration (A3).

Proceed with the settings and adjustments on the MASTER control board.

Operating modes

1 Either STEP-STEP or ONLY OPEN command.

Both leaves open.

2 PARTIAL/PEDESTRIAN OPENING command. Only the MASTER operator's leaf opens.

For the types of command that can be selected and paired to users, see the ENTERING USERS WITH ASSOCIATED COMMANDS.

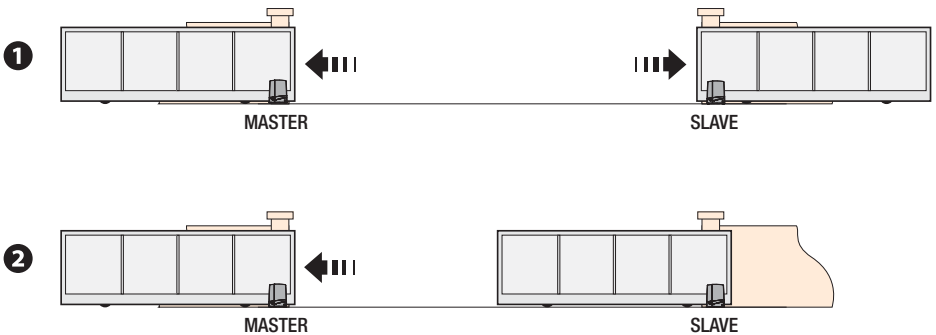

FINAL OPERATIONS

Once the electrical connections are done and the set up is finished, fasten the cables to the gearmotor jumper using a cable tie.

Fit the cover and fasten it to the sides using the screws.

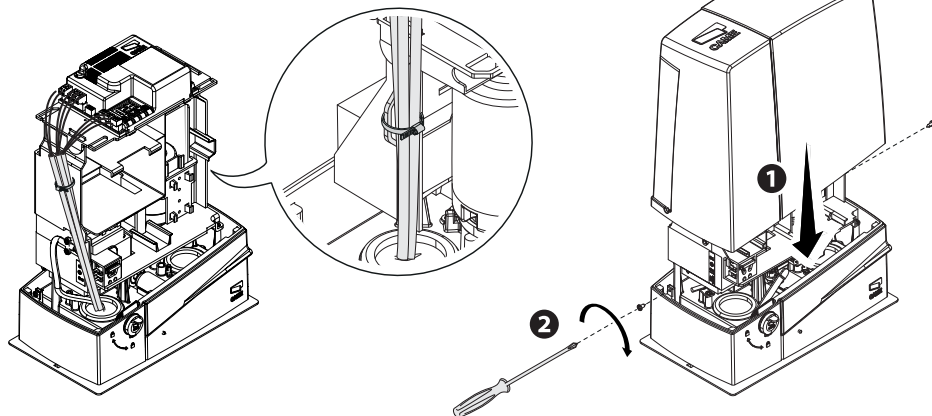

ERROR MESSAGE

 The error messages are shown on the display.

E 1	The travel calibration was interrupted when the STOP button was activated
E 2	Calibrating the complete gate-travel
E 3	Encoder broken
E 4	Services test error
E 7	Insufficient working time
E 9	Closing obstruction
E 10	Opening obstruction
E 11	Maximum number of detected obstructions
E 13	The NC contacts are open (for example, the limit-switches)
E 14	Serial communication error
E 17	Wireless system error
E 18	The wireless system configuration is missing

TROUBLESHOOTING

ISSUES	POSSIBLE CAUSES	FIXES
It neither opens nor closes	<ul style="list-style-type: none"> • Power supply is missing • The gearmotor is stuck • The transmitter doesn't work • The transmitter is broken • The stop button is either stuck or broken • The opening/closing button or the key-switch selector is stuck • The wireless accessory does not work 	<ul style="list-style-type: none"> • Check main power supply • Lock the gearmotor • Replace the batteries • Call for assistance • Call for assistance • Call for assistance
The gate opens but does not close	<ul style="list-style-type: none"> • The photocells are dirty 	<ul style="list-style-type: none"> • Clean and check proper functioning of the photocells

DISMANTLING AND DISPOSAL

 CAME CANCELLI AUTOMATICI S.p.A. applies a certified Environmental Management System at its premises, which is compliant with the UNI EN ISO 14001 standard to ensure the environment is safeguarded. Please continue safeguarding the environment. At CAME we consider it one of the fundamentals of our operating and market strategies. Simply follow these brief disposal guidelines:

DISPOSING OF THE PACKAGING

The packaging materials (cardboard, plastic, and so on) should be disposed of as solid household waste, and simply separated from other waste for recycling.

Always make sure you comply with local laws before dismantling and disposing of the product.

DISPOSE OF RESPONSIBLY!

DISMANTLING AND DISPOSAL

Our products are made of various materials. Most of these (aluminum, plastic, iron, electrical cables) are classified as solid household waste. They can be recycled by separating them before dumping at authorized city plants.

Whereas other components (control boards, batteries, transmitters, and so on) may contain hazardous pollutants. These must therefore be disposed of by authorized, certified professional services.

Before disposing, it is always advisable to check with the specific laws that apply in your area.

DISPOSE OF RESPONSIBLY!

REFERENCE REGULATIONS

CAME SpA declares that this product complies with the current directives at the time it is manufactured.

English - Manual FA00014-EN - v. 6 - 06/2017 - © CAMES.p.A.
The contents of this manual may change, at any time, and without notice.

CAME
safety&comfort

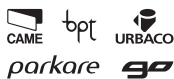

CAME S.p.A.

Via Martiri Della Libertà, 15
31080 **Dossan di Casier**
Treviso - Italy

☎ (+39) 0422 4940
📠 (+39) 0422 4941

Via Cornia, 1/b - 1/c
33079 **Sesto al Reghena**
Pordenone - Italy

☎ (+39) 0434 698111
📠 (+39) 0434 698434

www.came.com