

**РУССКИЙ** - Светодиодный светофор односекционный

**ENGLISH** - Led traffic light with one light

**ITALIANO** - Semaforo a led ad una luce

**DEUTSCH** - Ampel mit eins led lichtern

**ESPAÑOL** - Semáforo con led con uno luce



Инструкция - Instruction - Istruzioni - Anleitungen - Instrucciones

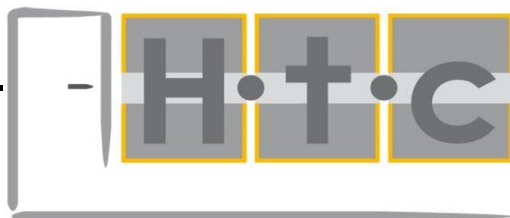

### **(RU) ТЕХНИЧЕСКИЕ ХАРАКТЕРИСТИКИ**

Электропитание: **мин. 8 В пост. тока / 9 В пер. тока - макс. 45 В пост. тока / 35 В пер. тока**

Масса: **1,23 кг.**

Цвет ламп: **красный, зеленый или желтый.**

Энергопотребление: **3 Вт.**

Средний срок службы светодиодов: **100 000 ч.**

Класс защиты: **IP 65**

### **(EN) TECHNICAL DATA SHEET**

Power supply: **min 8 V dc / 9 V ac - max 45 V dc / 35 V ac**

Weight: **1,23 Kg.**

Lens color: **Red, green, Yellow.**

Lamp consume: **3 W.**

Middle life lamp: **100.000 hours.**

Degree of protection: **IP 65**

### **(IT) CARATTERISTICHE TECNICHE**

Alimentazione elettrica: **min 8 V dc / 9 V ac - max 45 V dc / 35 V ac**

Peso: **1,23 Kg.**

Colore lenti: **Rosso, verde, giallo.**

Consumo lampada: **3 W.**

Durata media lampada: **100.000 ore.**

Grado di protezione: **IP 65**

### **(DE) TECHNISCHE EIGENSCHAFTEN**

Elektrische Ernährung: **min 8 V dc / 9 V ac - max 45 V dc / 35 V ac**

Gewicht: **1,23 Kg.**

Farbe langsam: **Rot, grün, gelb.**

Verbrauche Lampe: **3 W.**

Leben vermittelt Lampe: **100.000 Stunden.**

Maß an Schutz: **IP 65**

### **(FR) CARACTERISTIQUES TECHNIQUES**

Alimentation électrique: **min 8 V dc / 9 V ac - max 45 V dc / 35 V ac**

Poids: **1,23 Kg.**

Couleur verres: **Rouge, vert, jaune.**

Consommation lampe: **3 W.**

Durée moyenne lampe: **100.000 heures.**

Degré de protection: **IP 65**

### **H.T.C. GROUP SRL**

Via Milano, 8 - 20816 Ceriano Laghetto (MB)

Tel +39 02 96460902 Fax +39 02 96468606

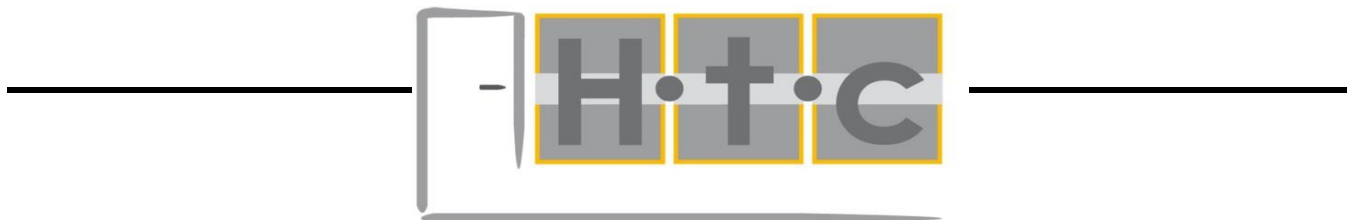

**(RU) ГАБАРИТНЫЕ РАЗМЕРЫ**

**(EN) DIMENSIONS**

**(IT) DIMENSIONI**

**(DE) DIMENSIONEN**

**(FR) DIMENSIONS**

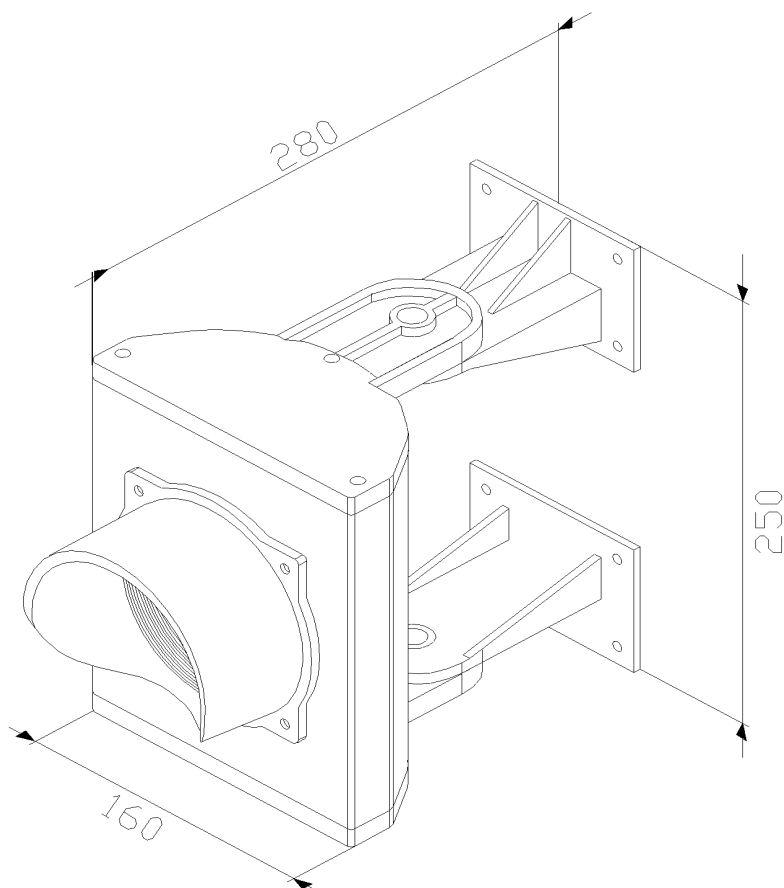

**H.T.C. GROUP SRL**

Via Milano, 8 - 20816 Ceriano Laghetto (MB)

Tel +39 02 96460902 Fax +39 02 96468606

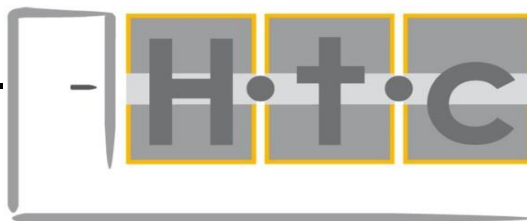

**СХЕМА СБОРКИ**  
**SCHEMA DI ASSEMBLAGGIO**  
**SCHEDULE OF ASSEMBLY**

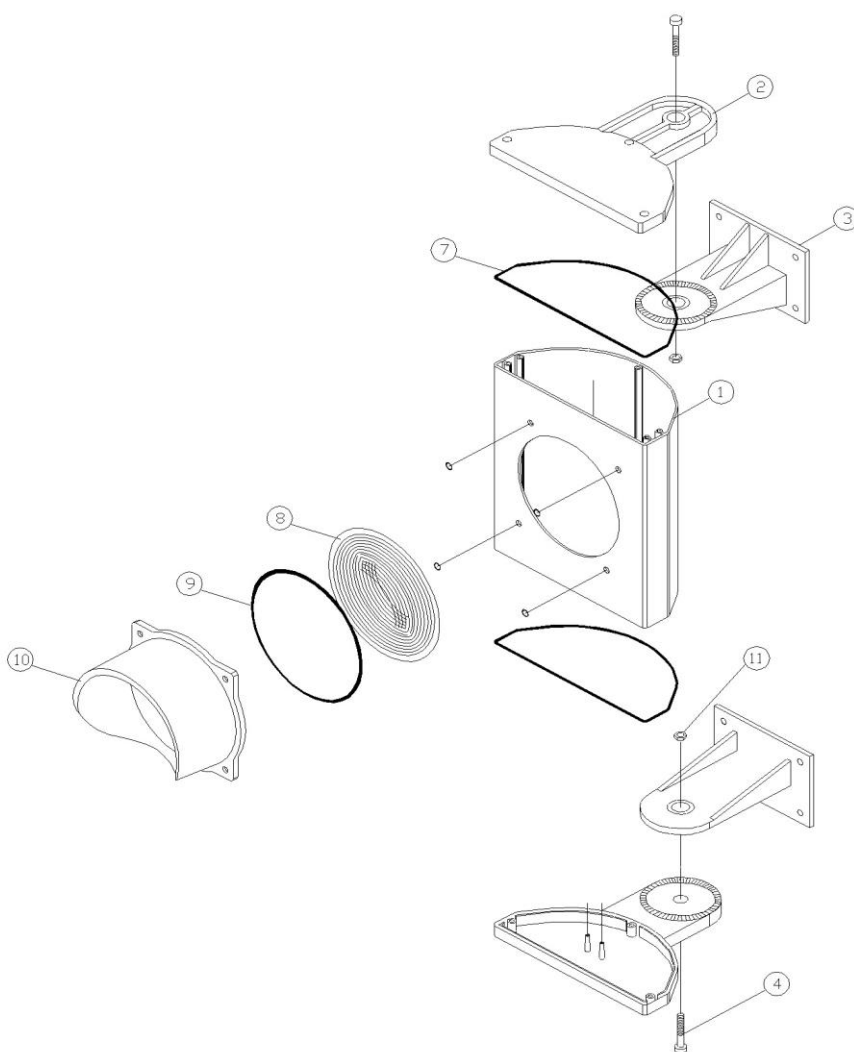

**H.T.C. GROUP SRL**  
Via Milano, 8 - 20816 Ceriano Laghetto (MB)  
Tel +39 02 96460902 Fax +39 02 96468606



**ЭЛЕКТРИЧЕСКАЯ СХЕМА**  
**SCHEMA ELETRICO**  
**ELECTRICAL DIAGRAM**

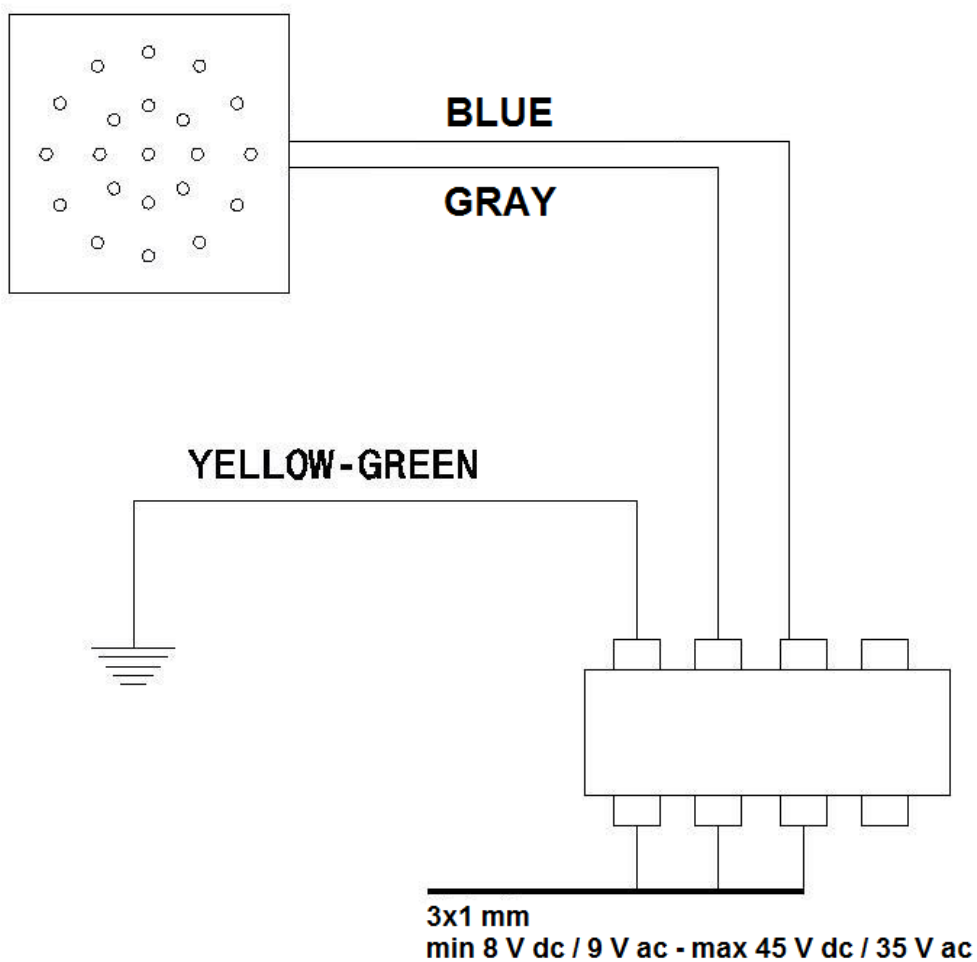

**H.T.C. GROUP SRL**  
Via Milano, 8 - 20816 Ceriano Laghetto (MB)  
Tel +39 02 96460902 Fax +39 02 96468606

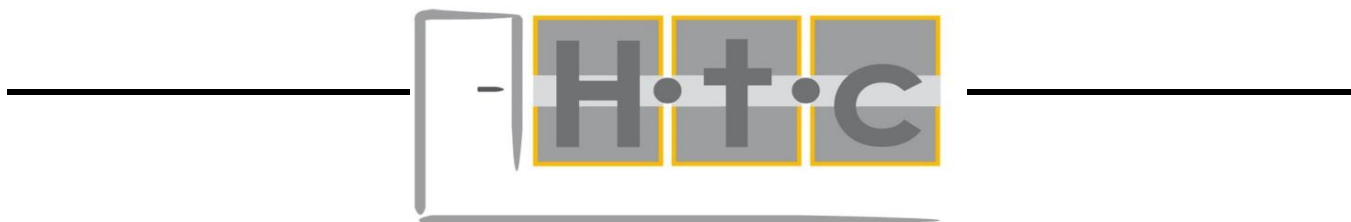

**(RU) ВОЗМОЖНЫЕ ПОЗИЦИИ**  
**(EN) ASSEMBLY POSITIONS**  
**(IT) POSIZIONI DI MONTAGGIO**  
**(DE) POSITIONIERST VON MONTAGE**  
**(FR) POSITIONS D'ASSEMBLAGE**  
**(ES) POSICIONES DE MONTAJE**

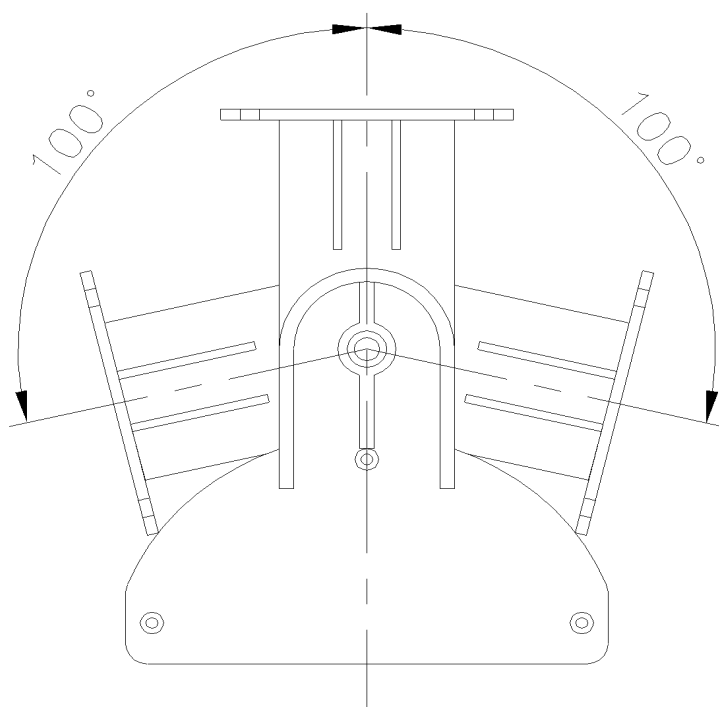

**H.T.C. GROUP SRL**  
Via Milano, 8 - 20816 Ceriano Laghetto (MB)  
Tel +39 02 96460902 Fax +39 02 96468606

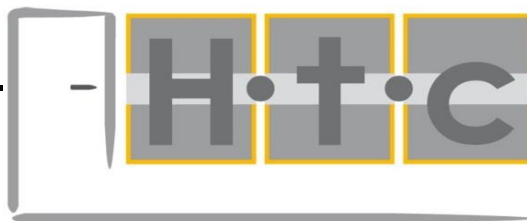

**(RU) ВНИМАНИЕ!**

- Перед подключением электрических кабелей убедитесь, что питание отключено.
- Светофоры должны устанавливаться только квалифицированным техническим персоналом.
- Использованные устройства содержат перерабатываемые материалы. Просьба сдавать использованные устройства на утилизацию.



**(EN) ATTENTION!**

- Before connecting the electrical cables make sure that the power supply is off.
- The traffic lights have to be installed by qualified technical staff only.
- Used vacuum cleaners still contain many recyclable materials. Therefore please take used vacuum cleaners to your retailer or recycling center so that they can be recycled.



**(IT) ATTENZIONE!**

- Prima di effettuare i collegamenti assicurarsi che l'alimentazione sia staccata.
- L'installazione deve essere effettuata da personale qualificato.
- Gli apparecchi dismessi contengono materiali preziosi. Si consiglia pertanto di restituire l'apparecchio dismesso al proprio rivenditore o presso centro di riciclaggio.



**(DE) ACHTUNG!**

- Bevor Sie die ampel berühren, versichern Sie sich dass die Spannung ausgeschaltet list.
- Die Installation darf nur von einem Fachmann ausgeführt werden.
- Altgeräte enthalten vielfach noch wertvolle materialien. Geben Sie deshalb Ihr ausgedientes Gerät bei ihrem händler bzw. einem Recyclingcenter zur Wiederverwertung ab.



**(FR) ATTENTION!**

- Avant d'effectuer les branchements électriques s'assur que l'alimentation soit débranchée.
- L'installation ne doit être effectuée que par du personnel qualifié.
- Les appareils usagés contiennent souvent des matériaux précieux. Remettez donc votre appareil usagé à votre revendeur or à un centre de recyclage pour la revalorisation.

**H.T.C. GROUP SRL**

Via Milano, 8 - 20816 Ceriano Laghetto (MB)  
Tel +39 02 96460902 Fax +39 02 96468606

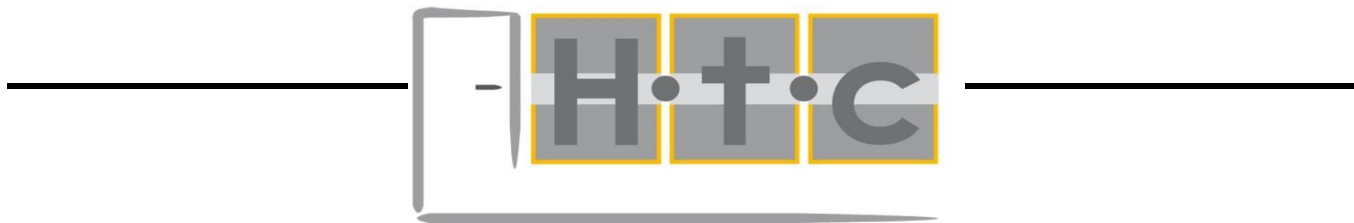

**H.T.C. GROUP SRL**

Via Milano, 8 - 20816 Ceriano Laghetto (MB)

Tel +39 02 96460902 Fax +39 02 96468606