

## Automatic road barriers

FA01918-EN

CE

EAC

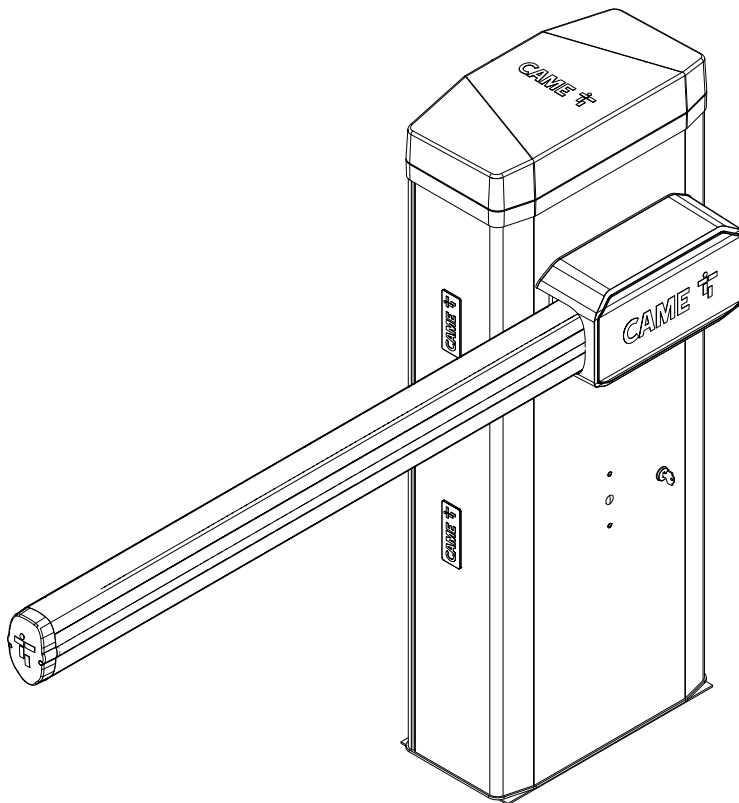

**GGT80AGS**  
**GGT80AX4**

**GGT80RGS**

**GGT80ACS**  
**GGT80AX6**

INSTALLATION MANUAL

EN

English



## DEVICE MANUAL RELEASE

⚠ Releasing the device may be dangerous for the user, if the boom fastening has been damaged or if the boom is no longer intact, as the result of an accident or installation error.

In these cases, the tensioned springs no longer guarantee that the boom is balanced. The boom may suddenly rotate when being released.

⚠ Manual release may cause the operator to move in an uncontrolled manner due to a mechanical fault or an imbalance.

📖 With the gearmotor released, the operator does not work.

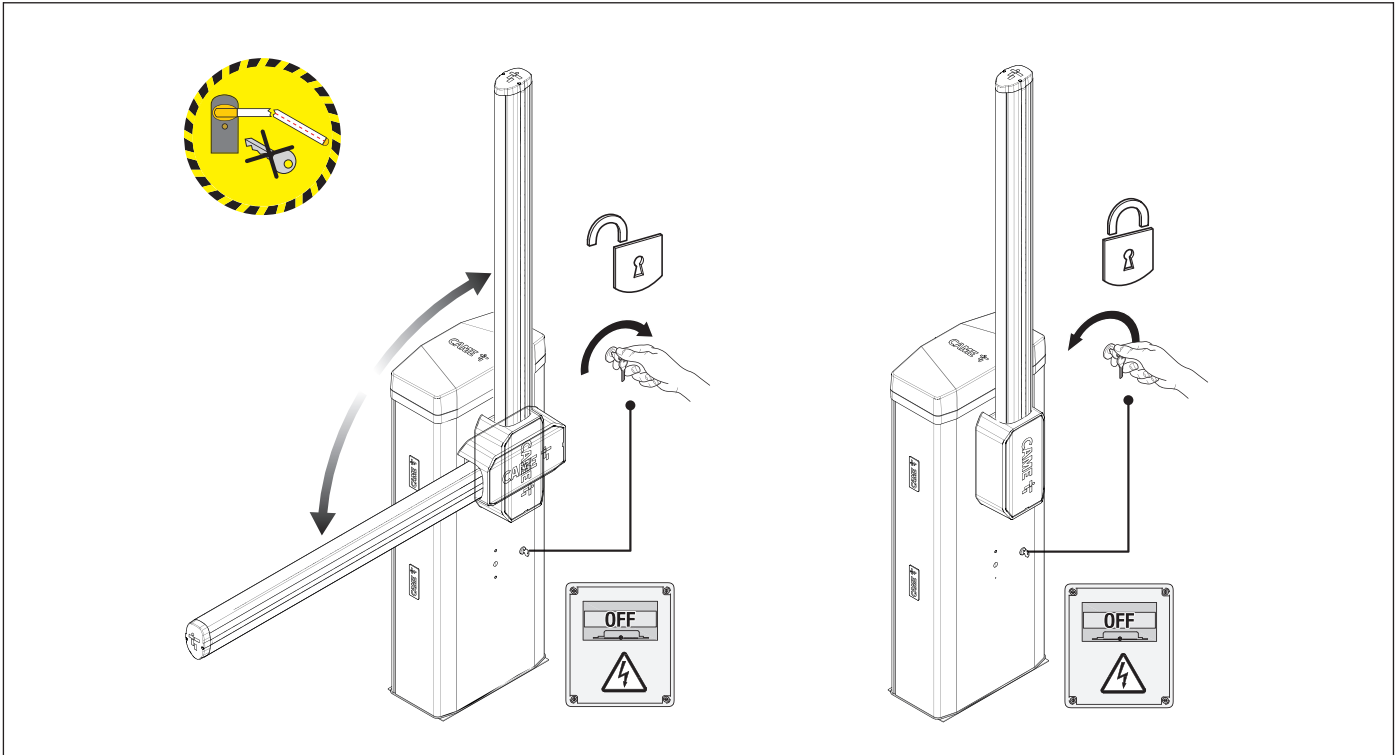

⚠ The balance springs must not be tensioned (boom vertical) when performing maintenance on the barrier.

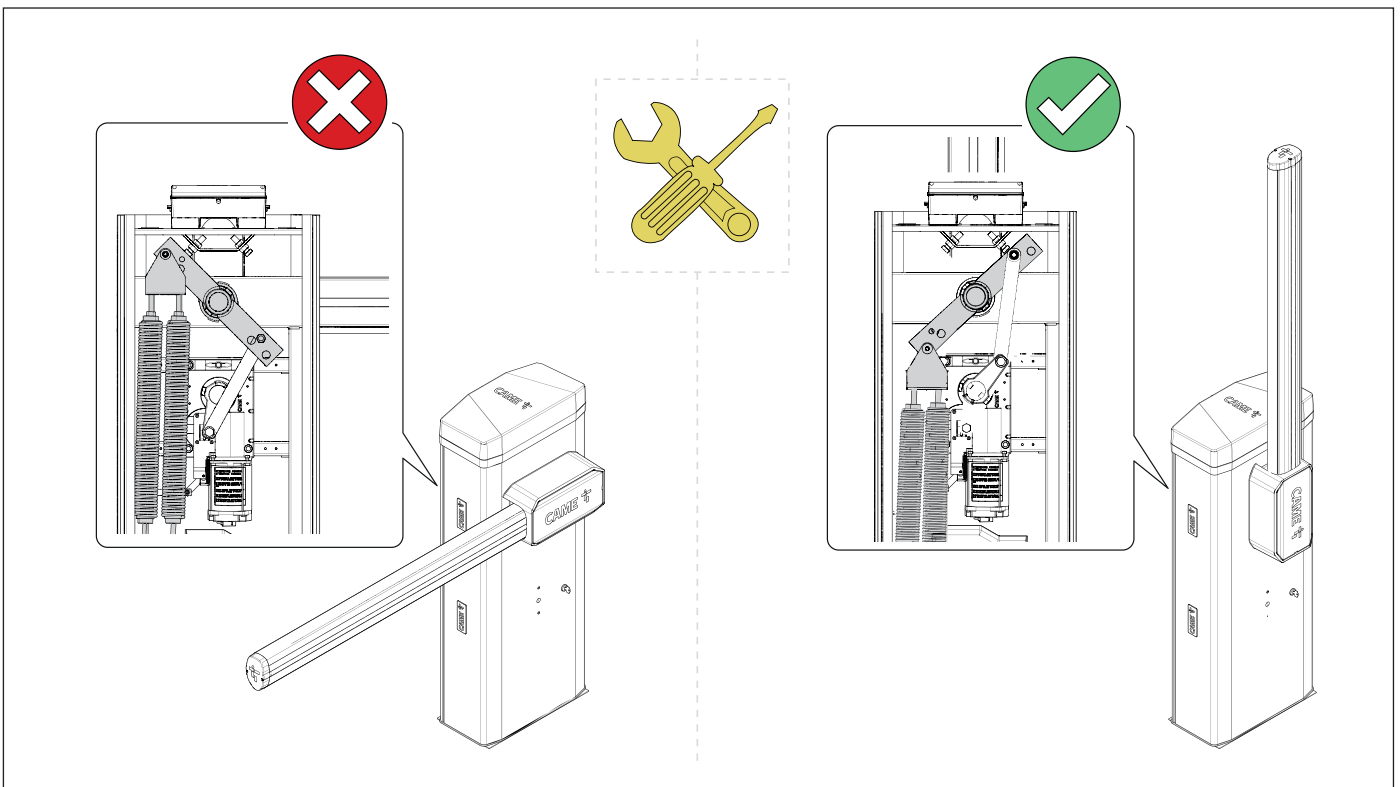

**⚠ Important safety instructions.****⚠ Please follow all of these instructions. Improper installation may cause serious bodily harm.****⚠ Before continuing, please also read the general precautions for users.**

Only use this product for its intended purpose. Any other use is hazardous.

- The manufacturer cannot be held liable for any damage caused by improper, unreasonable or erroneous use.
- This product is defined by the Machinery Directive (2006/42/EC) as partly completed machinery.
- Partly completed machinery means an assembly which is almost machinery but which cannot in itself perform a specific application.
- Partly completed machinery is only intended to be incorporated into or assembled with other machinery or other partly completed machinery or equipment thereby forming machinery to which the Machinery Directive (2006/42/EC) applies.
- The final installation must comply with the Machinery Directive (2006/42/EC) and the European reference standards in force.
- The manufacturer declines any liability for using non-original products, which would also void the warranty.
- All operations indicated in this manual must be carried out exclusively by skilled and qualified personnel and in full compliance with the regulations in force.
- The device must be installed, wired, connected and tested according to good professional practice, in compliance with the standards and laws in force.
- Make sure the mains power supply is disconnected during all installation procedures.
- Check that the temperature ranges given are suitable for the installation site.
- Make sure that opening the automatic barrier does not constitute a hazard.
- Do not install on slopes i.e. any surfaces that are not perfectly level.
- Do not install the operator on surfaces that could yield and bend. If necessary, add suitable reinforcements to the anchoring points.
- Make sure that no direct jets of water can wet the product at the installation site (sprinklers, water cleaners, etc.).
- Make sure you have set up a suitable dual-pole cut-off device along the power supply that is compliant with the installation rules. It should completely cut off the power supply according to category III surcharge conditions.
- Demarcate the entire site properly to prevent unauthorised personnel from entering, especially minors.
- In case of manual handling, have one person for every 20 kg that needs hoisting; for non-manual handling, use proper hoisting equipment in safe conditions.
- When the operator is being fixed in place, it may be unstable and overturn. Be careful and do not lean on it until it is fully fastened in place.
- Use suitable protection to prevent any mechanical hazards due to persons loitering within the operating range of the operator.
- The electrical cables must pass through special pipes, ducts and cable glands in order to guarantee adequate protection against mechanical damage.
- Make sure that the moving mechanical parts are suitably far away from the wiring.
- The electrical cables must not touch any parts that may overheat during use (such as the motor and transformer).
- All fixed controls must be clearly visible after installation, in a position that allows the guided part to be directly visible, but far away from moving parts. In the case of a hold-to-run control, this must be installed at a minimum height of 1.5 m from the ground and must not be accessible to the public.
- If the passage is wider than 3 m, you must use a fixed support for the boom.
- If not already present, apply a permanent tag that describes how to use the manual release mechanism close to it.
- Make sure that the operator has been properly adjusted and that the safety and protection devices and the manual release are working properly.
- Before handing over to the final user, check that the system complies with the harmonised standards and the essential requirements of the Machinery Directive (2006/42/EC).
- Any residual risks must be indicated clearly with proper signage affixed in visible areas, and explained to end users.
- Put the machine's ID plate in a visible place when the installation is complete.
- If the power supply cable is damaged, it must be immediately replaced by the manufacturer or by an authorised technical assistance centre, or in any case, by qualified staff, to prevent any risk.
- Keep this manual inside the technical folder along with the manuals of all the other devices used for your automation system.
- Make sure to hand over to the end user all the operating manuals of the products that make up the final machinery.
- The product, in its original packaging supplied by the manufacturer, must only be transported in a closed environment (railway carriage, containers, closed vehicles).
- If the product malfunctions, stop using it and contact an authorised support centre.

 The manufacture date is provided in the production batch printed on the product label. If necessary, contact us at <https://www.came.com/global/en/contact-us>.

 The general conditions of sale are given in the official CAME price lists.

## Main points of danger for people

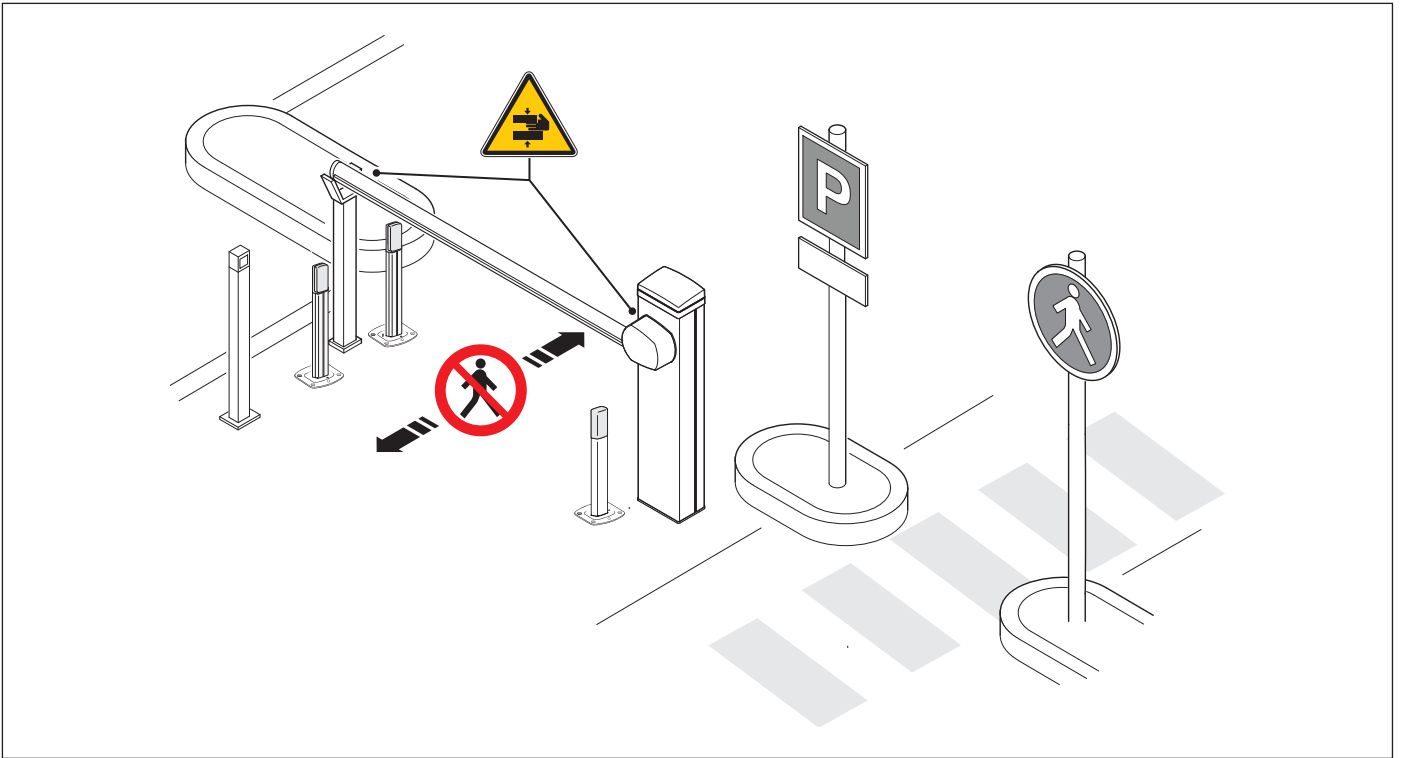

 Risk of trapping hands.

 No transiting.

## DISMANTLING AND DISPOSAL

 CAME S.p.A. employs an Environmental Management System at its premises. This system is certified and compliant with the UNI EN ISO 14001 standard to ensure that the environment is respected and safeguarded. Please continue safeguarding the environment. At CAME we consider it one of the fundamentals of our operating and market strategies. Simply follow these brief disposal guidelines:

### DISPOSING OF THE PACKAGING

The packaging materials (cardboard, plastic, etc.) can be disposed of easily as solid urban waste, separated for recycling.

Before dismantling and disposing of the product, please always check the local laws in force.

DISPOSE OF THE PRODUCT RESPONSIBLY.

### DISPOSING OF THE PRODUCT

Our products are made of various materials. Most of these materials (aluminium, plastic, iron and electrical cables) are classified as solid urban waste. They can be separated for recycling and disposed of at authorised waste treatment plants.

Other components (electronic boards, transmitter batteries, etc.) may contain pollutants.

These must be removed and disposed of by an authorised waste disposal and recycling firm.

It is always advisable to check the specific laws that apply in your area.

DISPOSE OF THE PRODUCT RESPONSIBLY.



## PRODUCT DATA AND INFORMATION

### Key

 This symbol shows which parts to read carefully.

 This symbol shows which parts describe safety issues.

 This symbol shows what to tell users.

 The measurements, unless otherwise stated, are in millimetres.

### Description

#### 803BB-0180

GGT80AGS - Automatic barrier with irreversible gearmotor 24 V DC with encoder; painted galvanised steel cabinet; accessories available. Balance springs included.

#### 803BB-0220

GGT80RGS - Automatic barrier with irreversible gearmotor 24 V DC with encoder; painted galvanised steel cabinet; accessories available. Balance springs included.

#### 803BB-0250

GGT80AX4 - Automatic barrier with irreversible gearmotor 24 V DC with encoder; satin-finish AISI 304 steel cabinet; accessories available. Balance springs included.

#### 803BB-0270

GGT80AX6 - Automatic barrier with irreversible gearmotor 24 V DC with encoder; satin-finish AISI 316 steel cabinet; accessories available. Balance springs included.

#### 803BB-0290

GGT80ACS - Automatic barrier with irreversible gearmotor 24 V DC with encoder; custom-RAL painted galvanised steel cabinet; accessories available. Balance springs included.

### Intended use

Ideal solution for apartment blocks and industrial applications

 Any installation and/or use other than that specified in this manual is forbidden.

### Usage limitations

| MODELS                       | GGT80AGS | GGT80RGS | GGT80AX4 | GGT80AX6 | GGT80ACS |
|------------------------------|----------|----------|----------|----------|----------|
| Max. net clearance width (m) | 7,8      | 7,8      | 7,8      | 7,8      | 7,8      |

### Technical data

| MODELS                      | GGT80AGS                                  | GGT80RGS                                | GGT80AX4                                  | GGT80AX6                                  | GGT80ACS                                  |
|-----------------------------|---|---|---|---|---|
| Power supply (V - 50/60 Hz) | 230 AC                                    | 120 AC                                  | 230 AC                                    | 230 AC                                    | 230 AC                                    |
| Maximum current draw (A)    | 1,1                                       | 2,2                                     | 1,1                                       | 1,1                                       | 1,1                                       |
| Motor power supply (V)      | 24 DC                                     | 24 DC                                   | 24 DC                                     | 24 DC                                     | 24 DC                                     |
| Standby consumption (W)     | 7   | 7                                       | 7   | 7   | 7   |
| Power (W)                   | 300                                       | 300                                     | 300                                       | 300                                       | 300                                       |
| Colour                      | 7024                                      | 7024                                    | -   | -   | RAL X                                     |
| Operating temperature (°C)  | -20 ÷ +55<br>(-40 with item<br>001PSRT01) | -20 to +55 (-40 with<br>item 001PSRT01) | -20 ÷ +55<br>(-40 with item<br>001PSRT01) | -20 ÷ +55<br>(-40 with item<br>001PSRT01) | -20 ÷ +55<br>(-40 with item<br>001PSRT01) |
| Torque (Nm)                 | 600                                       | 600                                     | 600                                       | 600                                       | 600                                       |
| Opening time at 90° (s)     | 4 ÷ 8                                     | 4 ÷ 8                                   | 4 ÷ 8                                     | 4 ÷ 8                                     | 4 ÷ 8                                     |
| Cycles/hour                 | 160                                       | 160                                     | 160                                       | 160                                       | 160                                       |
| Cycles/day                  | 2500                                      | 2500                                    | 2500                                      | 2500                                      | 2500                                      |
| Protection rating (IP)      | 54  | 54                                      | 54  | 54  | 54  |
| Insulation class            | I   | I                                       | I   | I   | I   |
| Weight (kg)                 | 90  | 90                                      | 90  | 90  | 90  |
| Storage temperature (°C)*   | -20 ÷ +70                                 | -20 ÷ +70                               | -20 ÷ +70                                 | -20 ÷ +70                                 | -20 ÷ +70                                 |
| Average life (cycles)**     | 3.000.000                                 | 3.000.000                               | 3.000.000                                 | 3.000.000                                 | 3.000.000                                 |

(\*) Before installing the product, keep it at room temperature where it has previously been stored or transported at a very high or very low temperature.

(\*\*) The average product life specified should be understood purely as an indicative estimate. It applies to normal usage conditions and where the product has been installed and maintained in compliance with the instructions provided in the CAME technical manual. The average product life is also affected, including significantly, by other variables such as, but not limited to, climatic and environmental conditions. The average product life should not be confused with the product warranty.

### Fuse table

| MODELS             | GGT80AGS | GGT80RGS | GGT80AX4 | GGT80AX6 | GGT80ACS |
|--------------------|----------|----------|----------|----------|----------|
| Line fuse          | 1.6 A-F  | 3.15 A-F | 1.6 A-F  | 1.6 A-F  | 1.6 A-F  |
| Accessory fuse     | 2 A-F    | 2 A-F    | 2 A-F    | 2 A-F    | 2 A-F    |
| Control board fuse | 4 A-F    | 4 A-F    | 4 A-F    | 4 A-F    | 4 A-F    |
| Motor fuse         | 10 A-F   | 10 A-F   | 10 A-F   | 10 A-F   | 10 A-F   |

## Description of parts

### Barrier

- 1 Cover
- 2 Boom anchoring plate
- 3 Intermediate plate
- 4 Fastening flange
- 5 Anti-shearing cover
- 6 Photocell holes
- 7 Lock for release
- 8 Cabinet
- 9 Inspection hatch
- 10 Inspection-hatch lock
- 11 Control panel
- 12 Safety microswitch with cover open
- 13 Mechanical stop for the boom adjustment
- 14 Lever arm
- 15 Gear motor with encoder
- 16 Auxiliary
- 17 Line fuse
- 18 Power supply terminal block
- 19 Anchoring plate
- 20 Anchoring bracket
- 21 Boom profile end cap
- 22 Spring anchoring pin
- 23 001G06080 - Balance spring  $\varnothing$  55 mm.
- 24 Released gearmotor safety microswitch
- 25 DIN rail

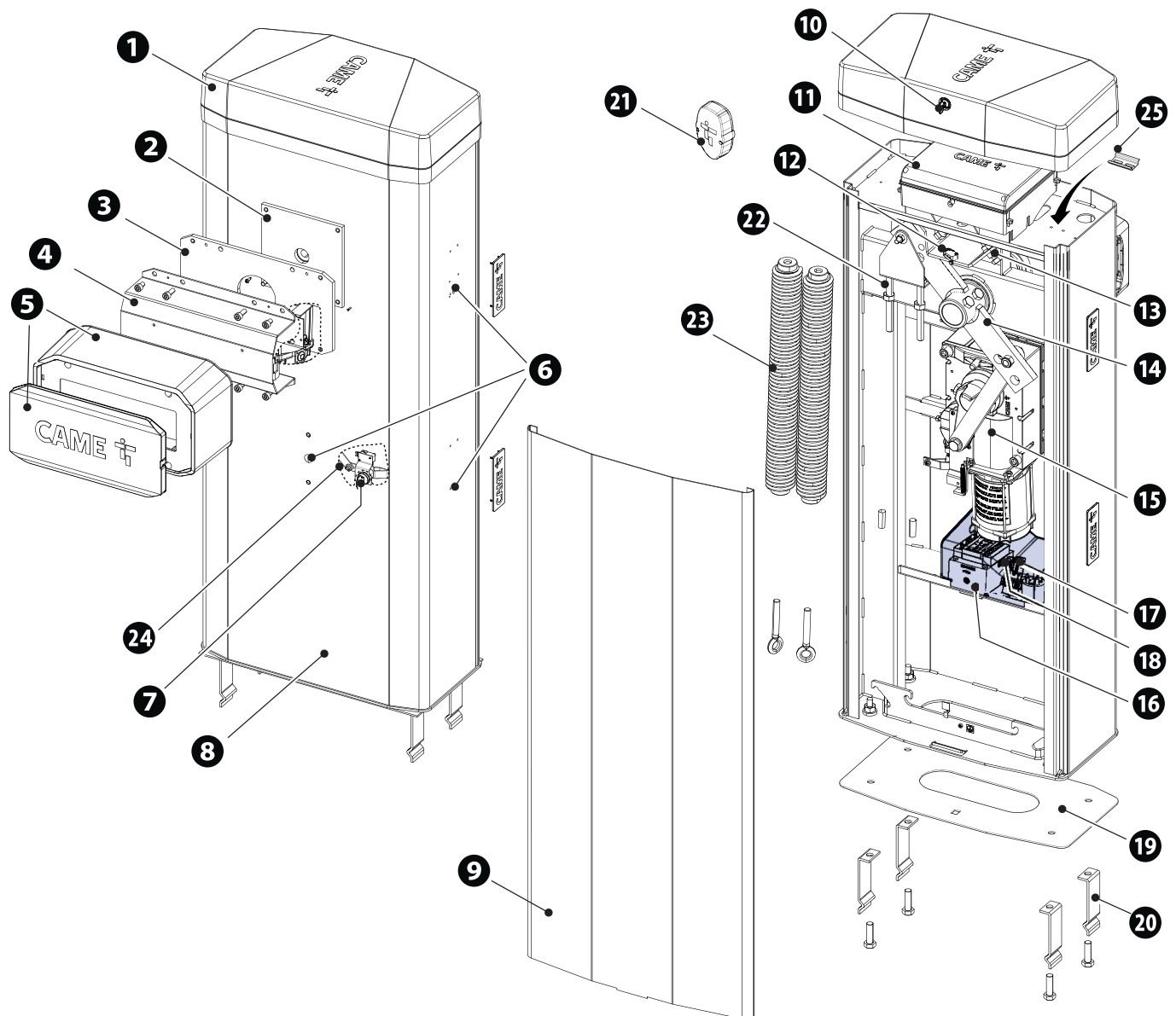

## Control board

- ❶ Programming buttons
- ❷ Terminal board for motor power supply
- ❸ Display
- ❹ Connector for plug-in radio frequency card (AF)
- ❺ Terminal board for connecting the antenna
- ❻ Terminal board for BUS accessories
- ❼ Connector for the R700 or R800 decoding card
- ❽ RSE\_1 connector for RSE card
- ❾ Terminal board for connecting the keypad selector
- ❿ Terminal board for connecting the transponder selector switch
- ⓫ Terminal board associated with the RSE\_1 connector for paired, alternate or CRP connection
- ⓬ Terminal board associated with the RSE\_2 connector for CRP connection, IO 485 card or Modbus RTU interface
- ⓭ Terminal board for connecting the electric lock
- ⓮ Terminal board for connecting the safety microswitch with cover open and gearmotor released (NC contact)
- ⓯ RSE\_2 connector for RSE card
- ⓰ Terminal board for connecting the warning LED strip
- ⓱ Terminal board for connecting control and safety devices
- ⓲ Terminal board for connecting the encoder
- ⓳ Accessories fuse
- ⓴ Terminal board for barrier status\*
- ⓵ Control board fuse
- ⓶ Terminal board for power supply to the control board
- ⓷ Motor fuse
- ⓸ Connector for CAME KEY
- ⓹ Memory Roll card connector

\* Only for ZL392 boards, version B

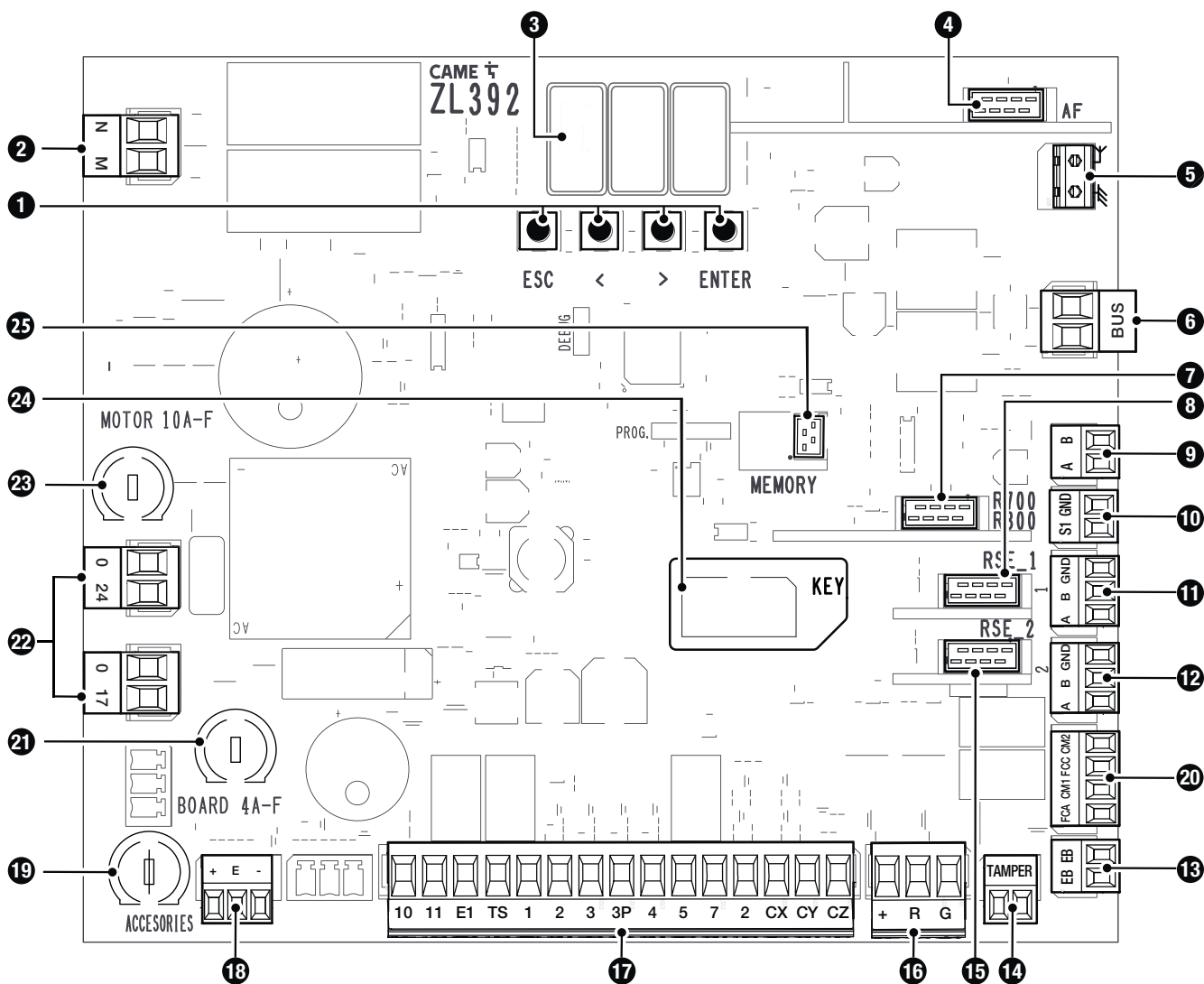

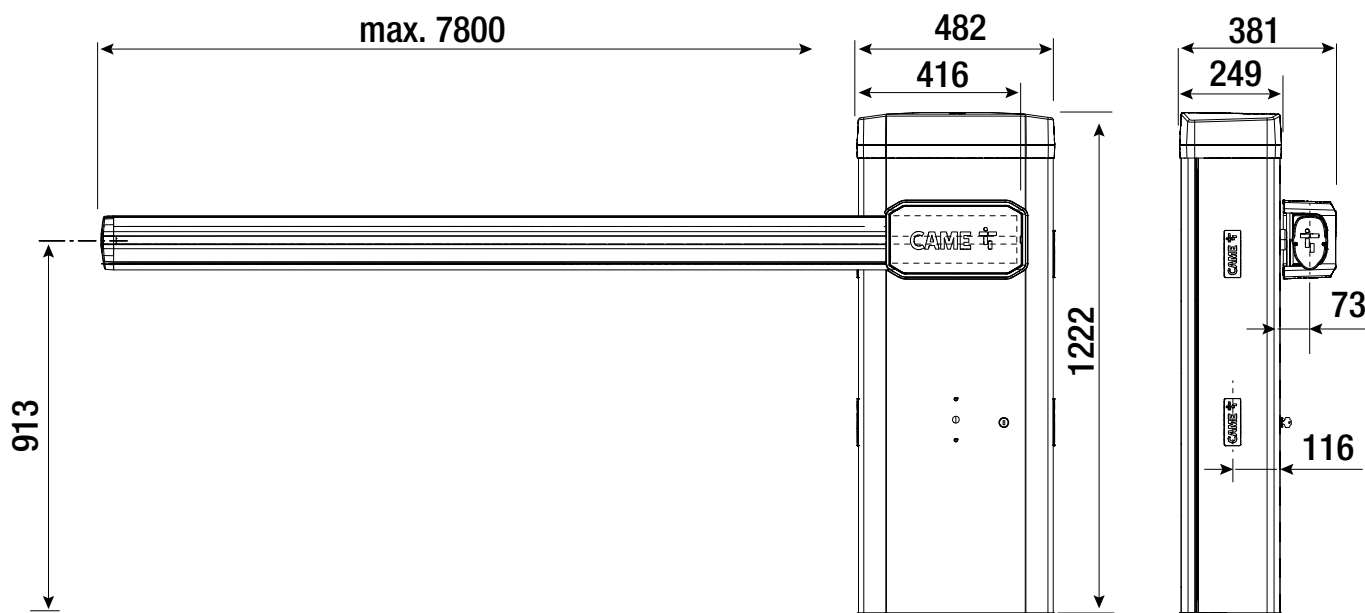

### Cable types and minimum thicknesses

| Cable length (m)            | up to 20                   | from 20 to 30              |
|-----------------------------|----------------------------|----------------------------|
| Power supply 230 V AC       | 3G x 1.5 mm <sup>2</sup>   | 3G x 2.5 mm <sup>2</sup>   |
| Power supply 120 V AC       | 3G x 1.5 mm <sup>2</sup>   | 3G x 2.5 mm <sup>2</sup>   |
| 24 V AC/DC flashing beacon  | 2 x 1 mm <sup>2</sup>      | 2 x 1 mm <sup>2</sup>      |
| TX Photocells               | 2 x 0.5 mm <sup>2</sup>    | 2 x 0.5 mm <sup>2</sup>    |
| RX photocells               | 4 x 0.5 mm <sup>2</sup>    | 4 x 0.5 mm <sup>2</sup>    |
| 24 V DC electric lock       | 2 x 1 mm <sup>2</sup>      | 2 x 1 mm <sup>2</sup>      |
| Command and control devices | *no. x 0.5 mm <sup>2</sup> | *no. x 0.5 mm <sup>2</sup> |

\* no. = see product assembly instructions - Warning: the cable cross-section is indicative and varies according to the motor power and cable length.

- To connect the antenna, use RG58 cable (up to 5 m).
- For installation in an outdoor environment, use cables with properties at least equivalent to those of type H05RN-F (with designation 60245 IEC 57).
- For installation in an indoor environment, use cables with properties at least equivalent to those of type H05VV-F (designation to 60227 IEC 53).
- If the cable lengths differ from those specified in the table, define the cable cross-sections according to the actual power draw of the connected devices and in line with regulation CEI EN 60204-1.
- For multiple, sequential loads along the same line, recalculate the values in the table according to the actual power draw and distances. For information on connecting products not covered in this manual, please see the documentation accompanying the products themselves.
- For paired and CRP connection, use a UTP CAT5 cable. Maximum length 1000 metres.

| Single branch length (m) | max. 50 m             |
|--------------------------|-----------------------|
| BUS cable                | 2 x 1 mm <sup>2</sup> |

- The total length of all branches can be a maximum of 150 m.
- The cable cannot be shielded.

### Wind resistance

- The table shows the boom wind-load resistance.
- The value relates to the boom only and does not refer to any applicable accessories.
- Resistance class with reference to the EN 13241 standard.

| Type                      | Boom 4.4 m | Boom 6.4 m | Boom 8 m |
|---------------------------|------------|------------|----------|
| Resistance class          | 4          | 3          | 2        |
| Wind pressure [Pa]        | 1100       | 600        | 400      |
| Maximum wind speed [km/h] | 160        | 120        | 100      |

## INSTALLATION

 The following illustrations are examples only. The space available for fitting the operator and accessories varies depending on the area where it is installed. It is up to the installer to find the most suitable solution.

In case of manual handling, have one person for every 20 kg that needs hoisting; for non-manual handling, use proper hoisting equipment in safe conditions. When the operator is being fixed in place, it may be unstable and overturn. Be careful and do not lean on it until it is fully fastened in place.

### Preliminary operations

 If the flooring does not allow the device to be fastened in a solid and stable way, lay a cement slab. Dig a hole for the foundation frame. Set up the corrugated tubes needed for the wiring coming out of the junction pit.

 The number of tubes depends on the type of system and the accessories that are going to be fitted.

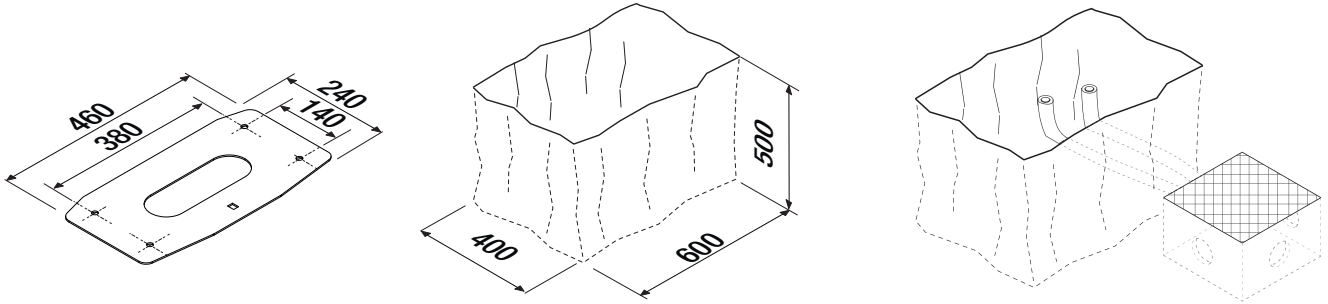

### Laying the anchoring plate

Set up a foundation frame that is larger than the anchoring plate. Fit an iron cage in the foundation frame to reinforce the concrete. Assemble the anchoring braces to the plate.

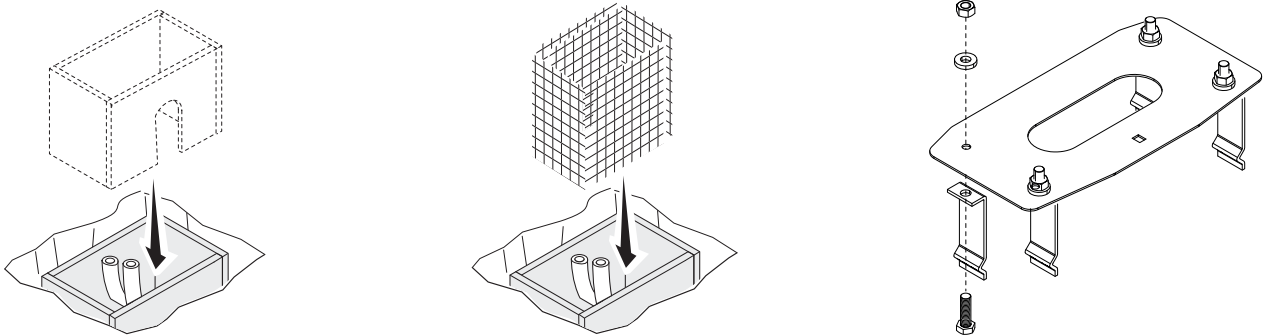

Fit the anchoring plate in the iron cage.

 The tubes must pass through the existing holes. Cast cement into the foundation frame.

 The plate must be perfectly level and the screw threads completely above surface.

Wait at least 24 hours for the cement to dry.

Remove the foundation frame.

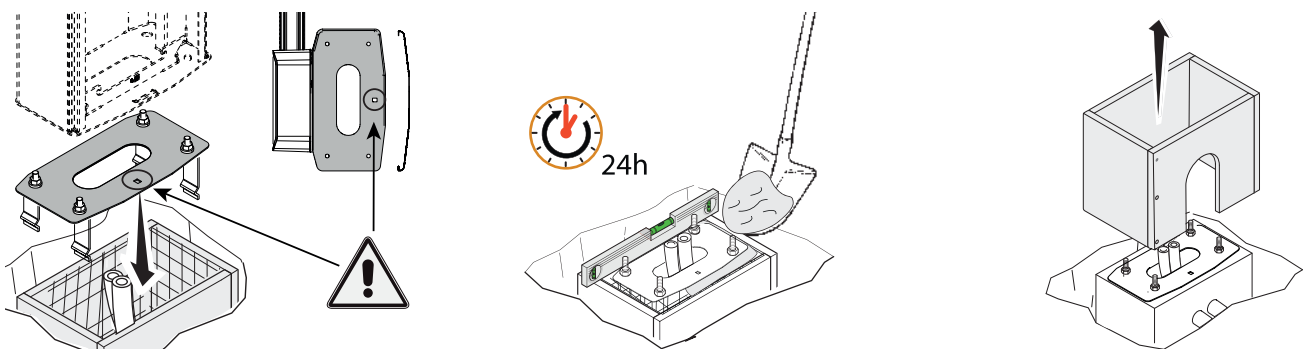

Fill the hole with soil around the concrete block.  
 Remove the nuts from the screws.  
 Thread the electrical cables into the tubes so that they protrude by about 1500 mm.

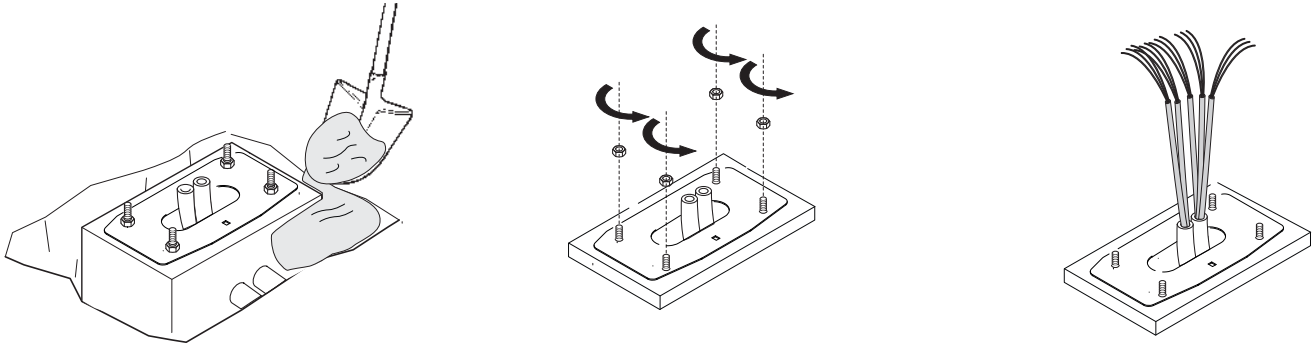

## Preparing the barrier

With the inspection hatch open, the operator does not work.

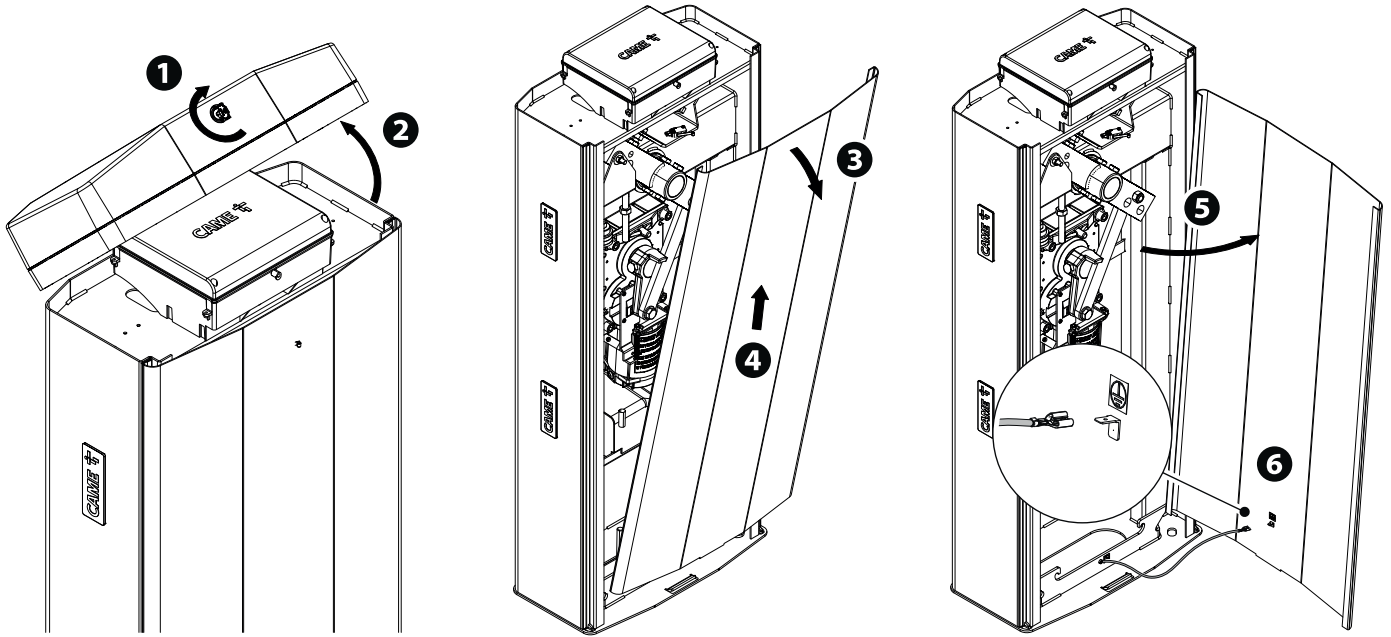

## Fastening the barrier

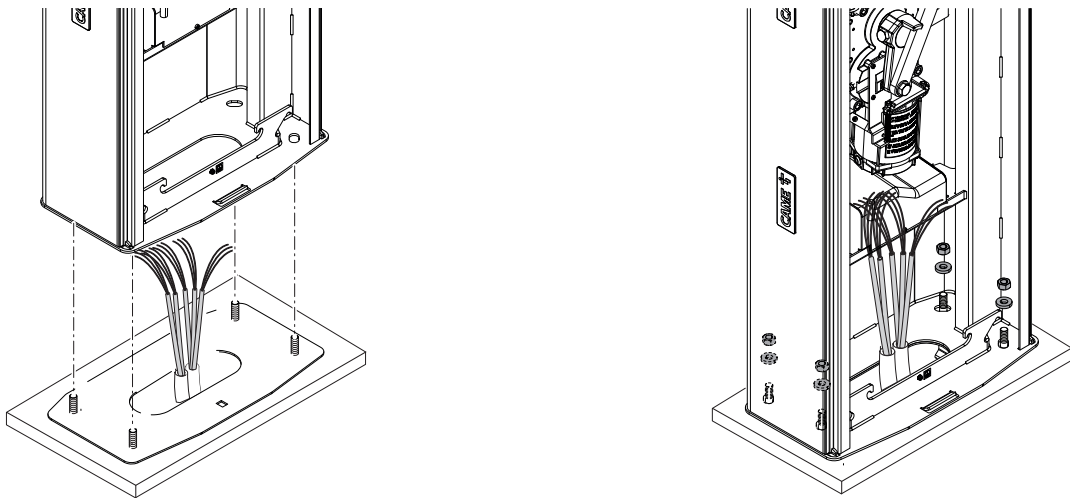

## Changing the boom opening direction

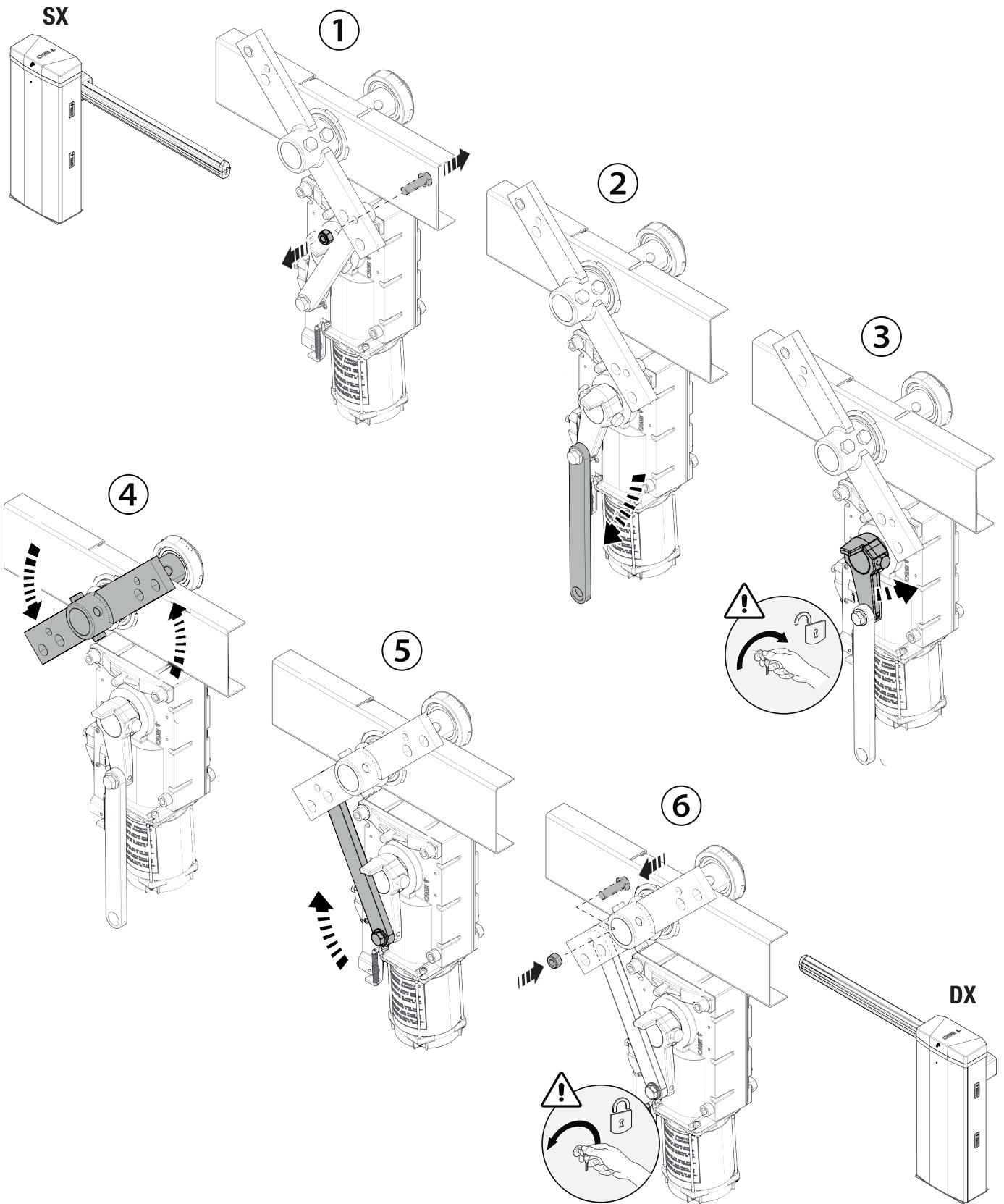



## Boom installation

Insert the reinforcement inside the boom.

Fix the flange and the intermediate plate to the boom.

 First install the LED strip (where applicable), ONLY THEN fix the flange and the intermediate plate.

 Tighten the screws using a torque wrench and a torque of 20 Nm.

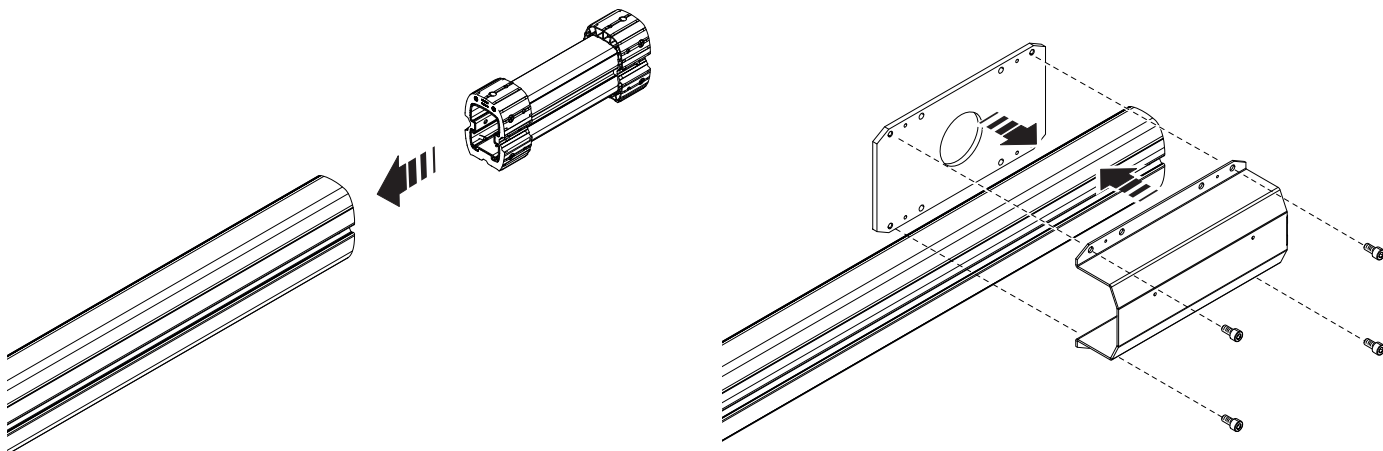

Fix the boom to the anchoring plate.

 Tighten the screws using a torque wrench and a torque of 20 Nm.

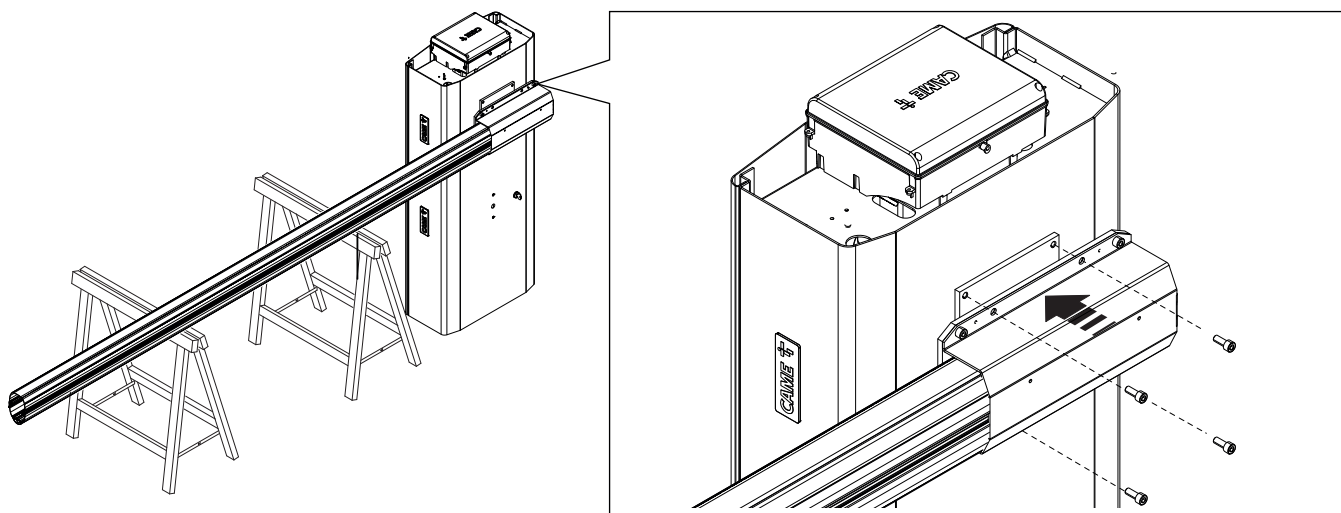



- 1 Cut the slot-cover profiles to the same size as the boom slot minus 10 millimetres.
- 2 Insert the slot-cover profiles into the grooves on both sides of the boom.
- 3 Insert the anti-impact rubber profile into the groove.
- 4 Cut off the excess part of the profile.
- 5 Use the screws to fasten the boom end cap.
- 6 Fit the anti-shearing protective cover onto the boom-attachment cover and fasten it using the screws supplied.

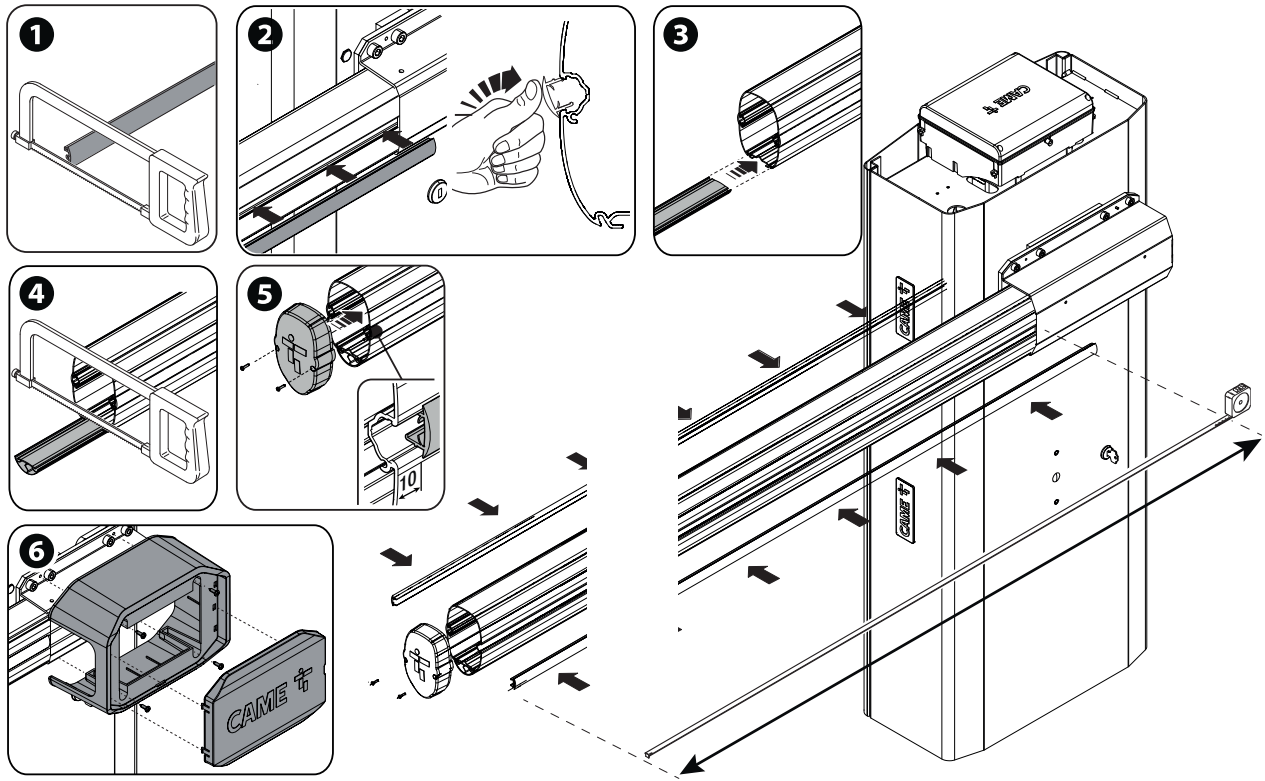

### Choosing the hole for fixing the balance spring

| Passage width clearance (m)                           | 4,00 < 4,50 | 4,50 < 5,00 | 5,00 < 5,50 | 5,50 < 6,00 | 6,00 < 6,50 | 6,50 < 7,00 | 7,00 < 7,80 |
|---|-------------|-------------|-------------|-------------|-------------|-------------|-------------|
| Boom with LED strip                                   | A           | A           | B           | A A         | A A         | A A         | B B         |
| Boom with LED strip and single skirt*                 | B           | A A         | A A         | B B         | B B         | B B         | -           |
| Boom with LED strip and full-height skirt             | A A         | A A         | B B         | B B         | -           | -           | -           |
| Boom with LED strip and swing rest                    | A           | B           | A A         | A A         | A A         | A A         | -           |
| Boom with LED strip, single skirt and swing rest      | A A         | A A         | A A         | -           | -           | -           | -           |
| Boom with LED strip, full-height skirt and swing rest | A A         | B B         | B B         | -           | -           | -           | -           |

Simple boom means the boom complete with slot cover, cap and rubber profile.

If the passage is wider than 4 m, you must use a support for the boom (fixed or mobile).

Single skirt (803XA-0340):

- max 2 modules for a 4 metre boom
- max 3 modules for a 6 metre boom
- max 4 modules for up to a 7 metre boom

Full-height skirt (803XA-0350):

- max 2 modules for a 4 metre boom.
- max 3 modules for a 6 metre boom.

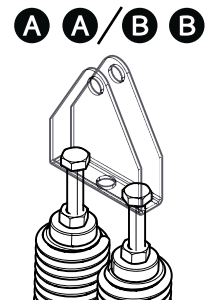
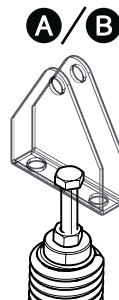
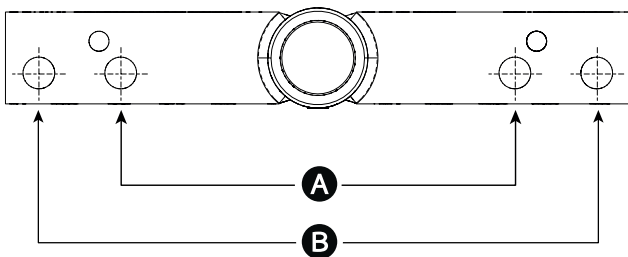



## Assembling the balance spring

- ① Hex-head screw M12 x 120
- ② Top spring attachment
- ③ Bushing Ø13.8
- ④ Washer M8
- ⑤ Hex-head screw M8 x 45
- ⑥ Bushing Ø19
- ⑦ M8 self-locking nut
- ⑧ M12 nut

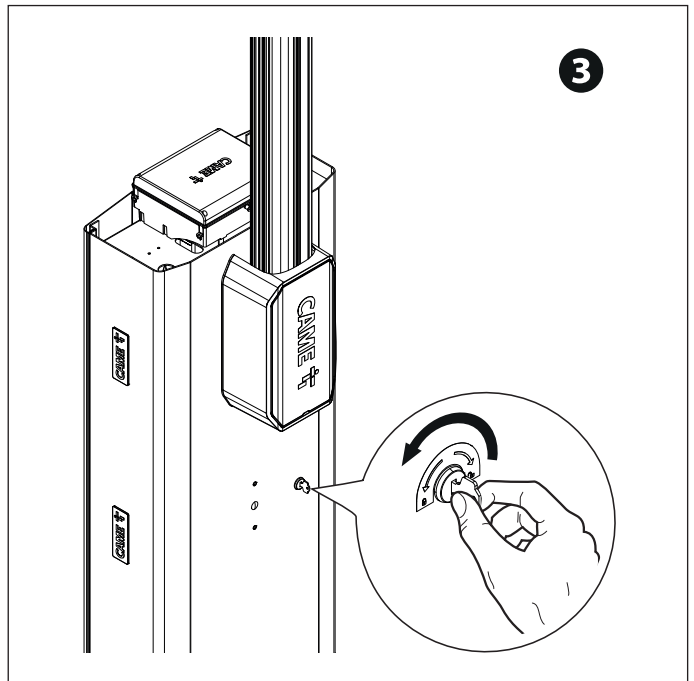
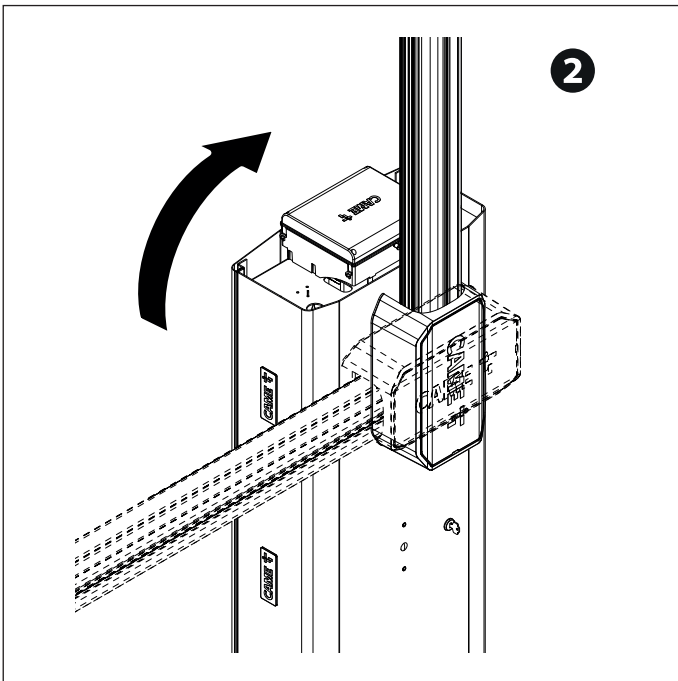
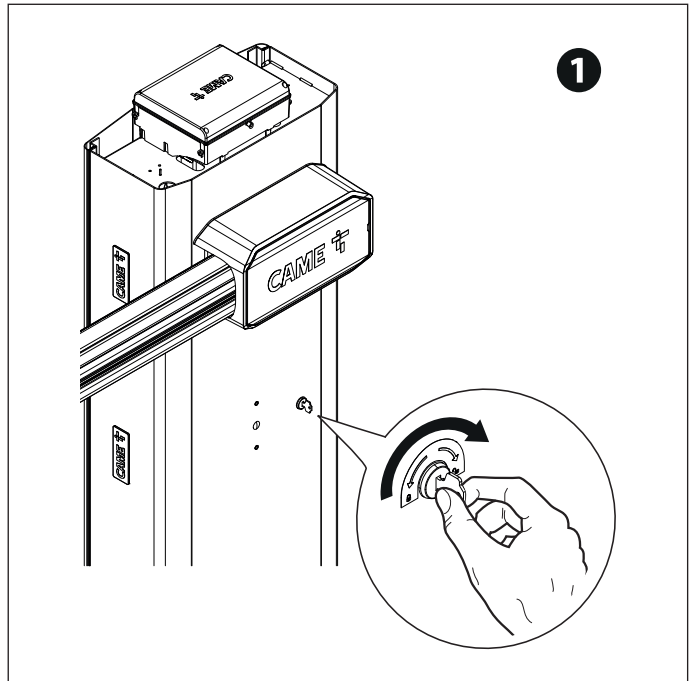
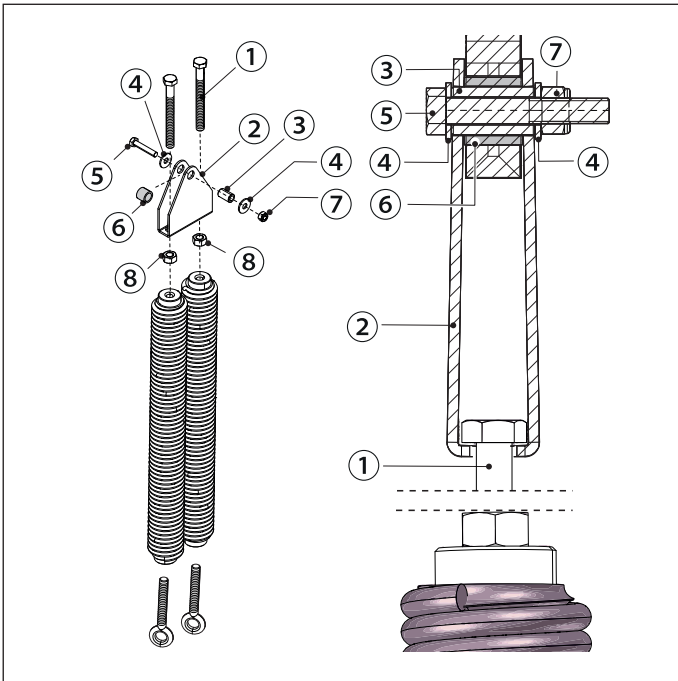
- ① Release the gearmotor.
- ② Position the boom vertically.
- ③ Lock the gearmotor
- ④ ⑤ ⑥ Assemble the anchoring pin and fix it on the lever arm.
- ⑦ Tighten the eyelet tie rod to the lower part of the spring.
- ⑧ Screw the spring to the anchoring pin.
- ⑨ Hook the eyelet rod onto the anchoring bracket.

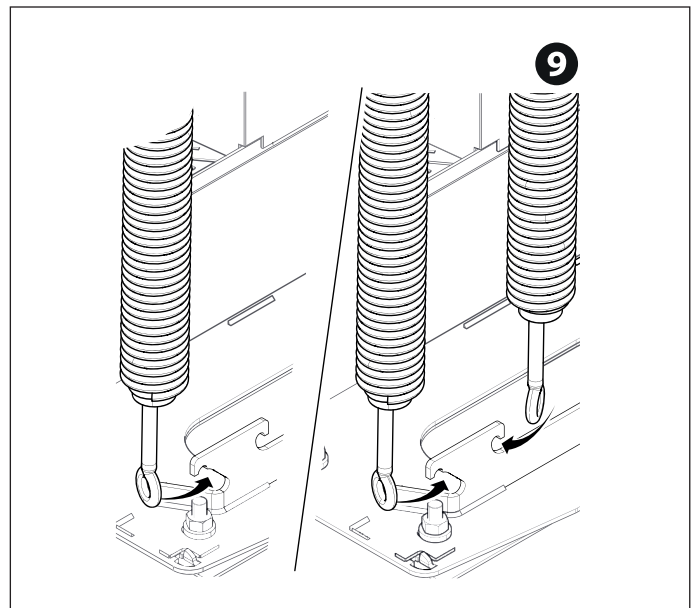
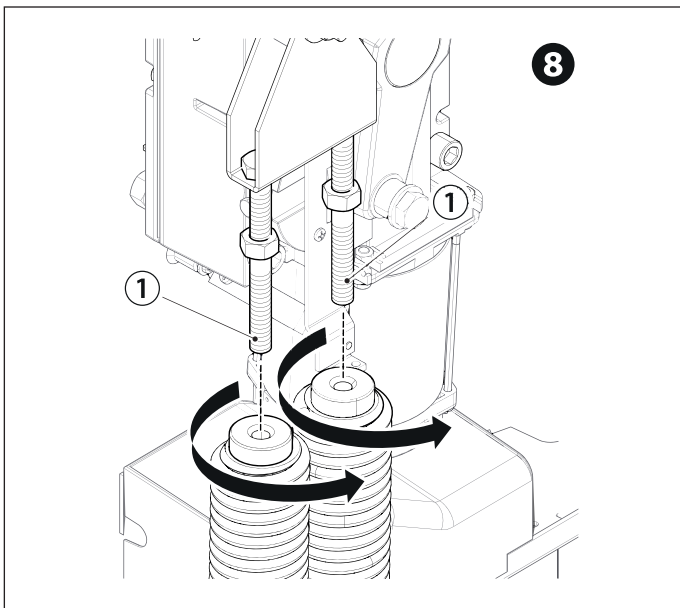
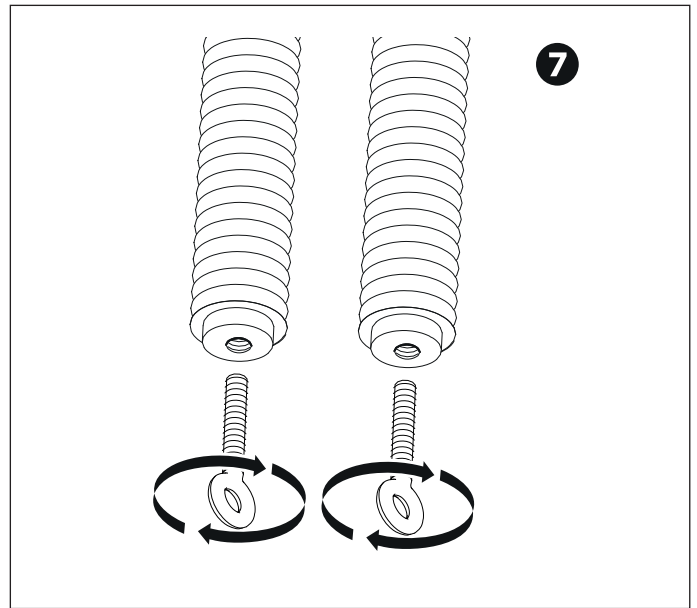
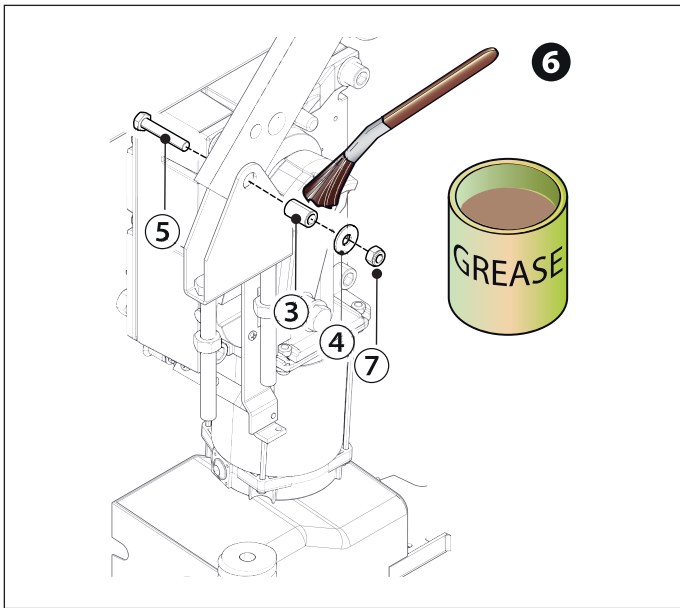
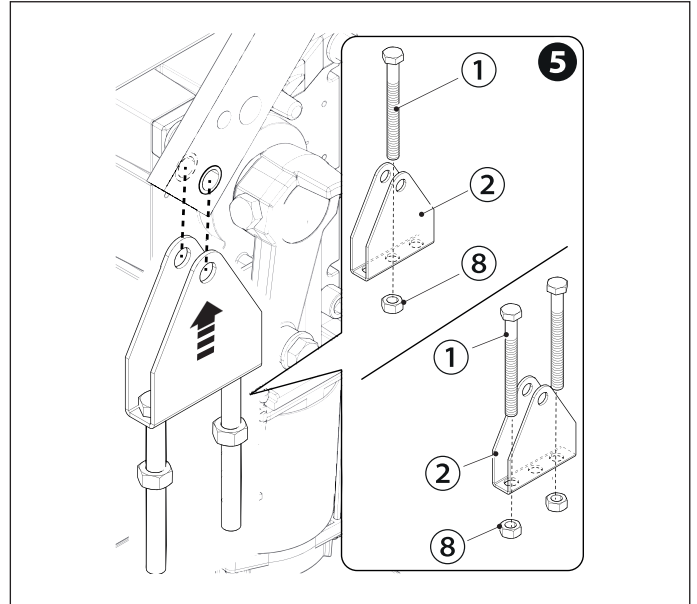
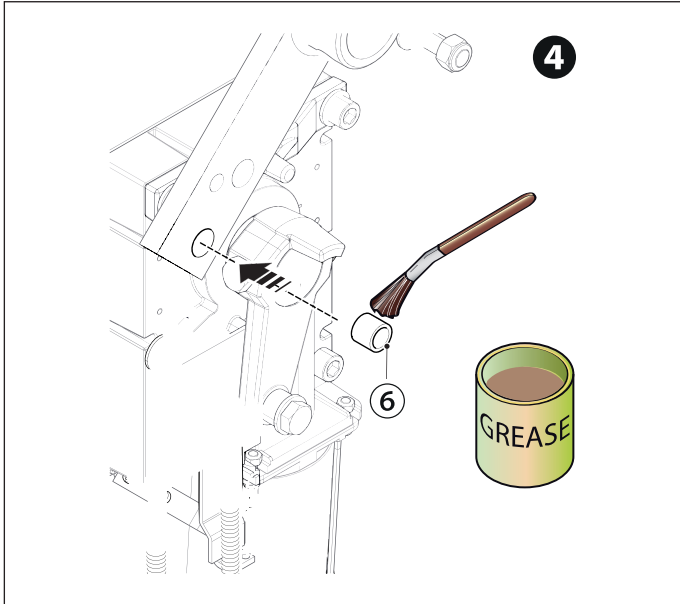



 Lubricate the spring when it is fully extended.

## Balancing the boom

❶ Release the gearmotor.

❷ Manually turn the spring to increase or reduce the traction. The boom should stabilise at 45°.

📖 Where there are two springs, carry out the procedure on both springs at the same time.

❸ Fasten the locknut.

Position the boom vertically.

❹ Lock the gearmotor

📖 Check the proper working state of the spring. When the boom is vertical, the spring is not taut. When the boom is horizontal, the spring is taut.

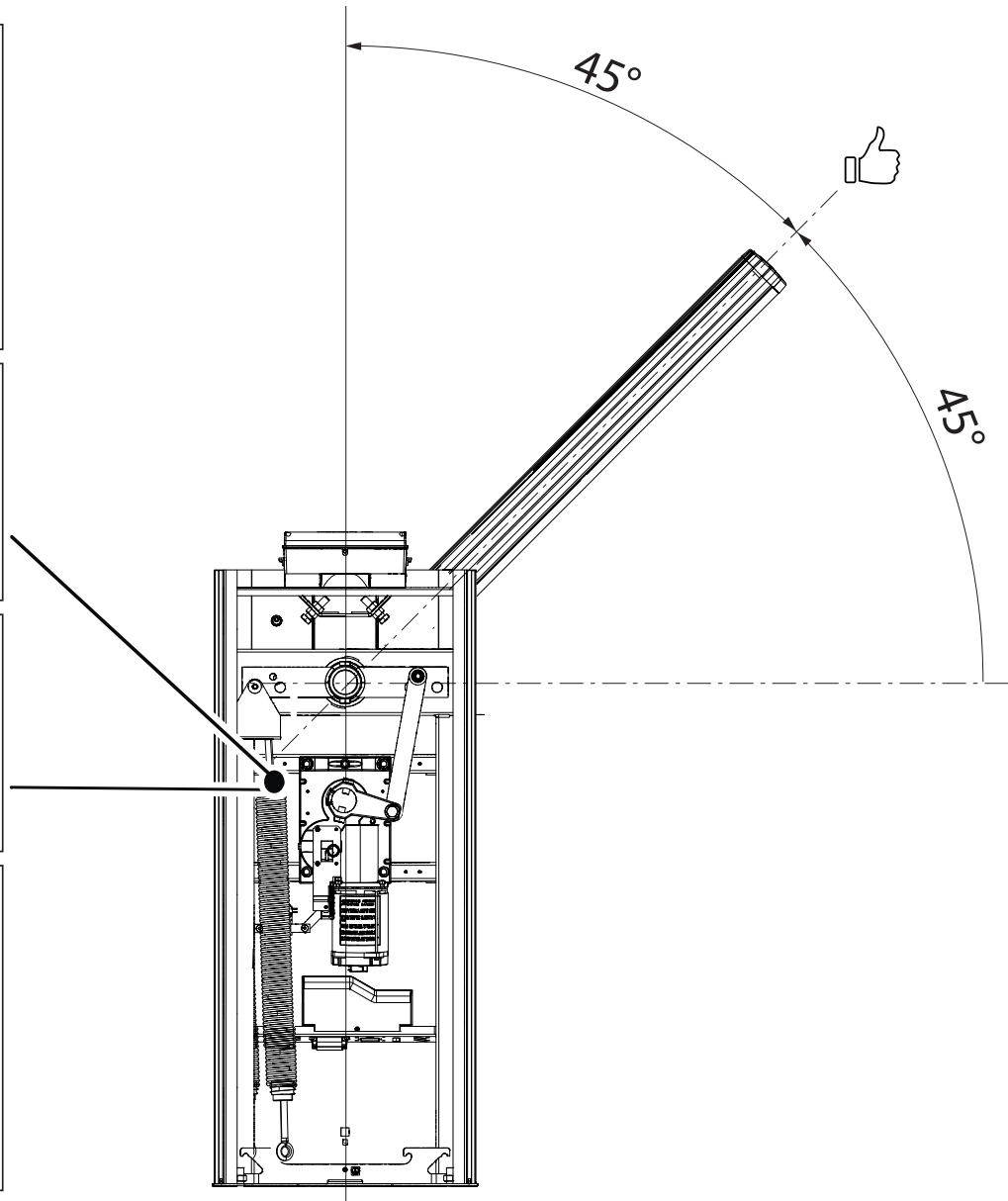
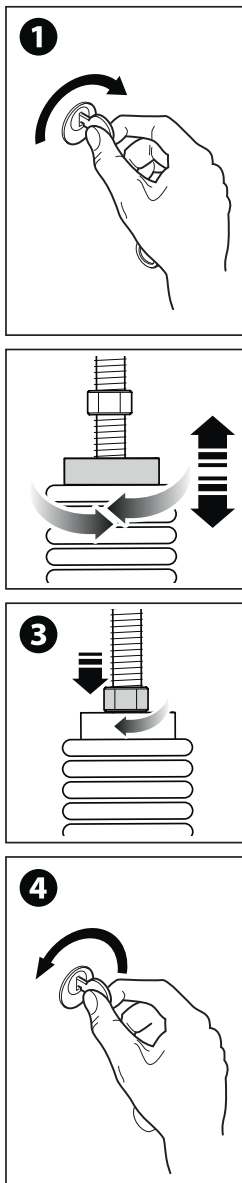

## Determining the travel end points with mechanical limit switches

Check that the boom is parallel to the road surface when it is in the closed position and at about 89° when it is in the open position.

### Correct the boom's horizontal position

Release the gearmotor.

Open the inspection hatch.

- 1 Turn the mechanical stop until you reach the desired boom position.
- 2 Fasten the mechanical stop with a locknut.

Lock the gearmotor

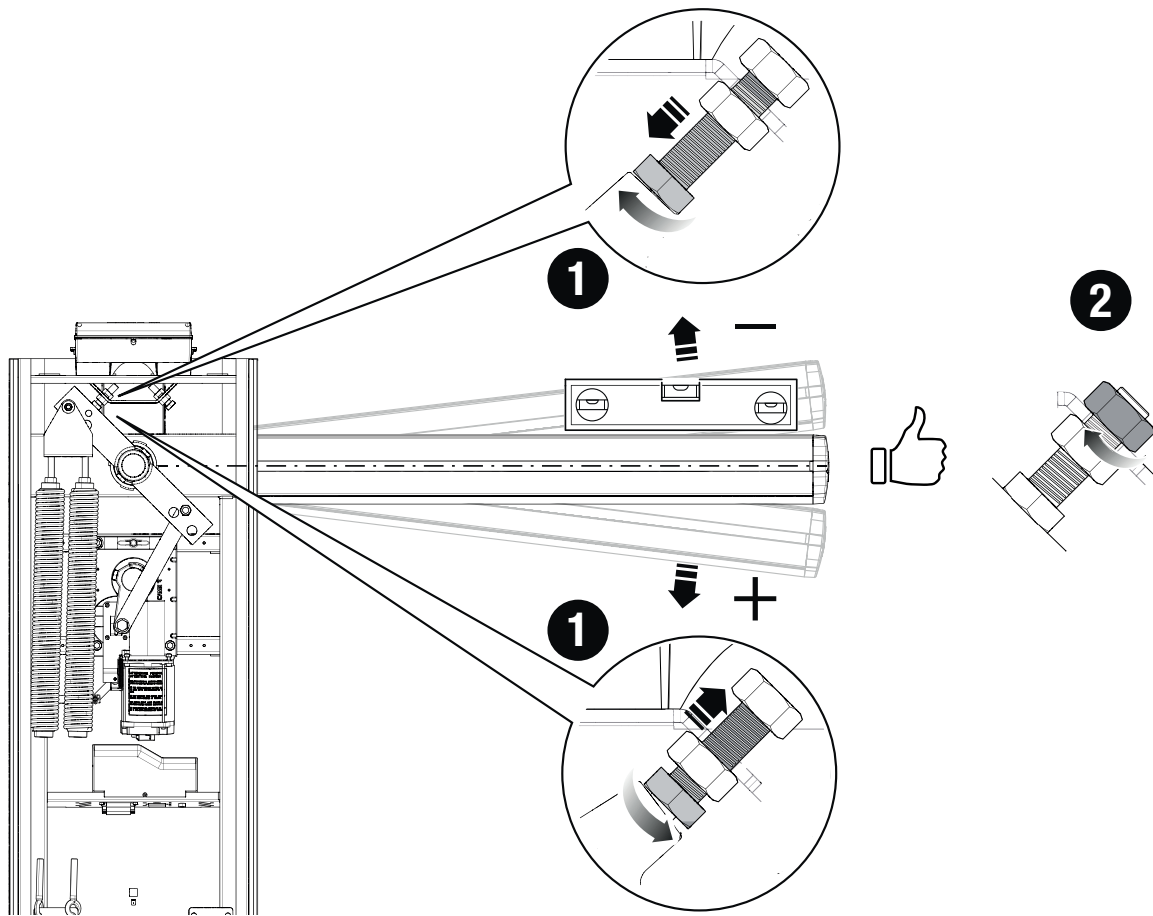

## Correct the boom's vertical position

Release the gearmotor.

Open the inspection hatch.

➊ Turn the mechanical stop until you reach the desired boom position.

➋ Fasten the mechanical stop with a locknut.

Lock the gearmotor.

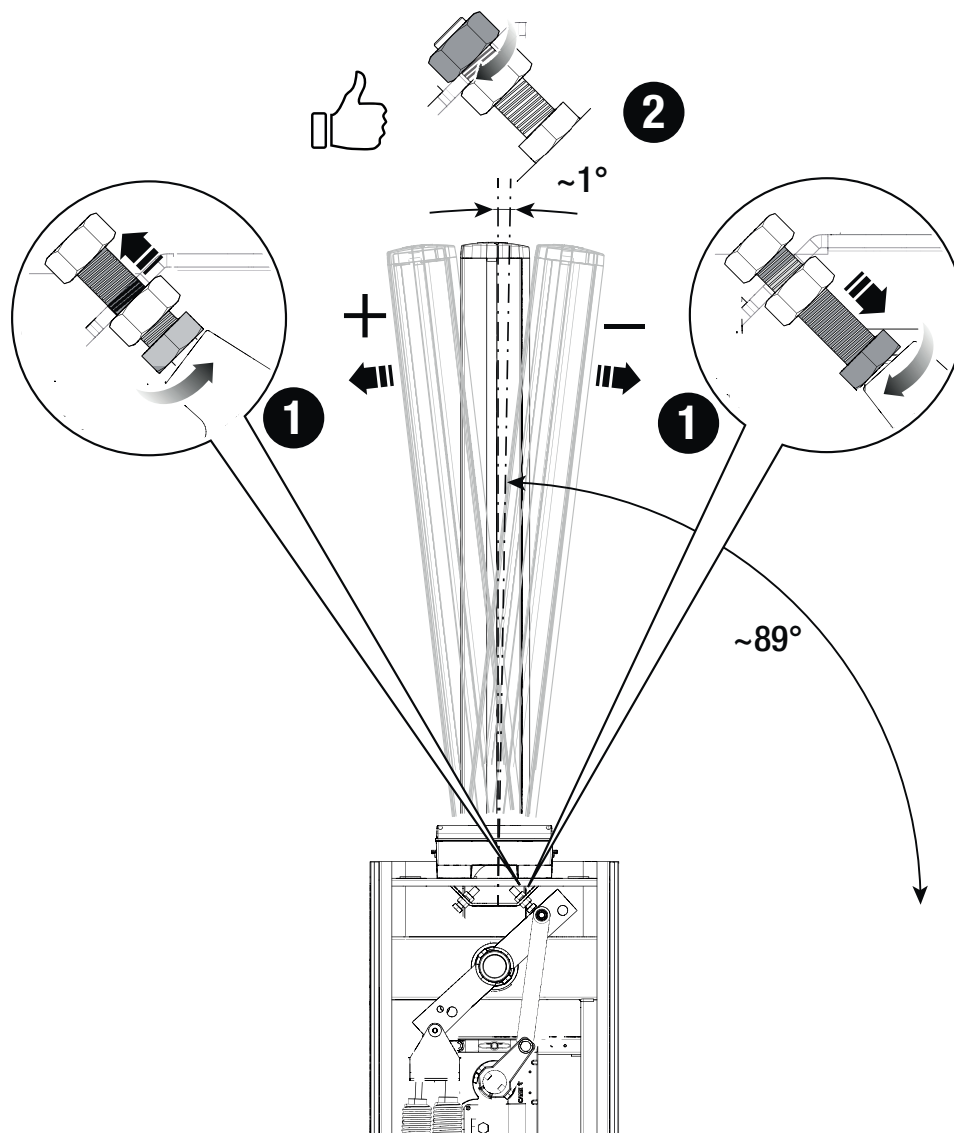

## ELECTRICAL CONNECTIONS

### Passing the electrical cables

The electrical cables must not touch any parts that may overheat during use (such as the motor and transformer).  
Make sure that the moving mechanical parts are suitably far away from the wiring.

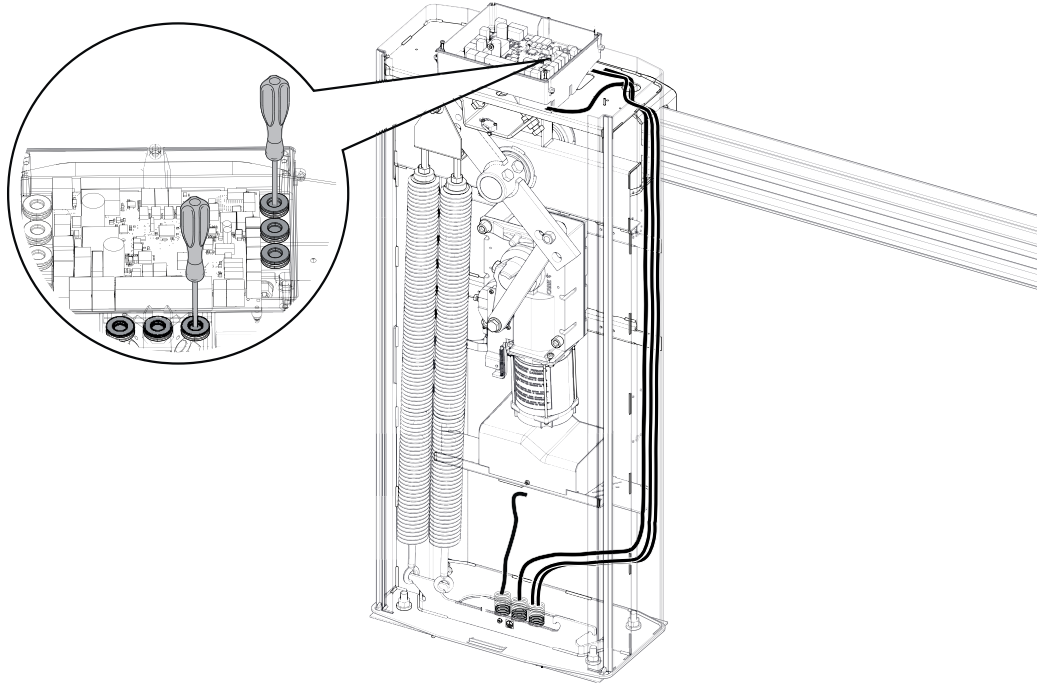

### Power supply

Make sure the mains power supply is disconnected during all installation procedures.

⚠ Before working on the control panel, disconnect the mains power supply and remove the batteries, if any.

#### Connecting to the electrical network

- ⓕ Line fuse
- Ⓛ Phase
- Ⓝ Neutral
- Ⓧ Earth
- ⓔ Ferrite

Apply the ferrite supplied to the power supply cable.  
Ferrite type p.n. ECQK922091.

📖 The cable must pass through the ferrite twice (2 turns).

#### Power supply output for accessories

The output normally delivers 24 V AC.

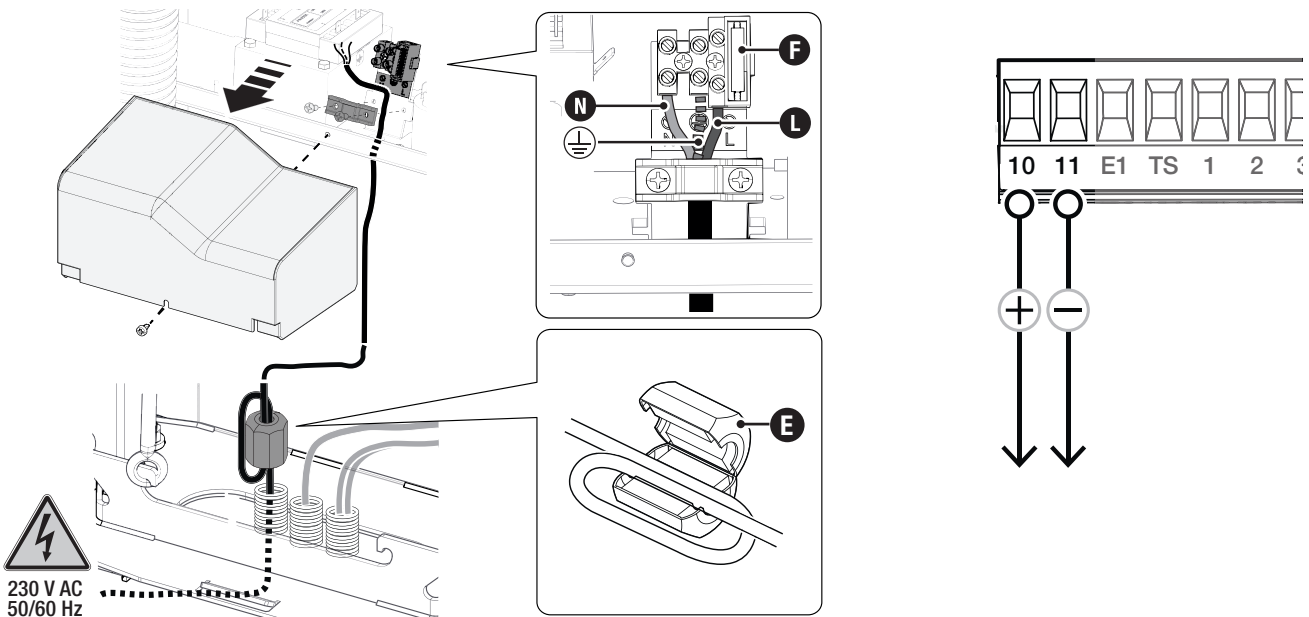

230 V AC  
50/60 Hz

## Maximum capacity of contacts

 The total power of the outputs listed below must not exceed the maximum output power [Accessories]

| Device                        | Output  | Power supply (V) | Power (W) |
|-------------------------------|---------|------------------|-----------|
| Accessories                   | 10 - 11 | 24 AC            | 40        |
| Additional light              | 10 - E1 | 24 AC            | 25        |
| Flashing beacon               | 10 - E1 | 24 AC            | 25        |
| Operator status warning light | 10 - 5  | 24 AC            | 3         |
| LED strip                     | +RG     | 24 DC            | 12        |

The outputs deliver 24 V DC when the batteries start operating, if they are installed.

| Device  | Output | Power supply (V) | Power (W) |
|---------|--------|------------------|-----------|
| BUS CXN | BUS    | 15 DC            | 15        |

 Only connect CAME devices with CXN BUS system



## Command and control devices

### 1 STOP button (NC contact)

This stops the operator and excludes automatic closing. Use a control device to resume movement.

When the contact is being used, it must be activated during programming.

See the [F1 – Total stop] function.

### 2 Control device (NO contact)

Open command

When the [F6 – Hold-to-run] function is active, a control device must be set to OPEN.

### 3 Control device (NO contact)

Partial Opening command

The contact must only be used for operators working in paired mode.

### 4 Control device (NO contact)

Close command

When the function [F6 - Hold-to-run] is active, a control device must be set to CLOSE.

### 5 Control device (NO contact)

Step-by-step command

### 6 Card reader

Insert the R700 card into the corresponding connector.

### 7 Transponder selector switch

Insert the R700 card into the corresponding connector.

### 8 Keypad selector

Insert the R800 card into the corresponding connector.

### 9 Antenna with RG58 cable

If the chosen signalling device can be fitted with an antenna, use the terminal shown to connect it.

Insert the AF card into the corresponding connector for remote control with transmitter.

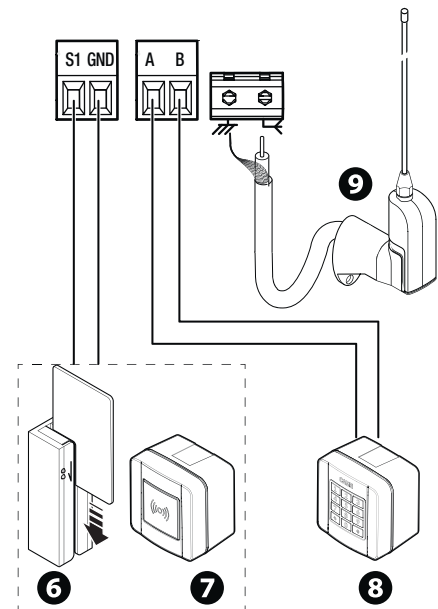
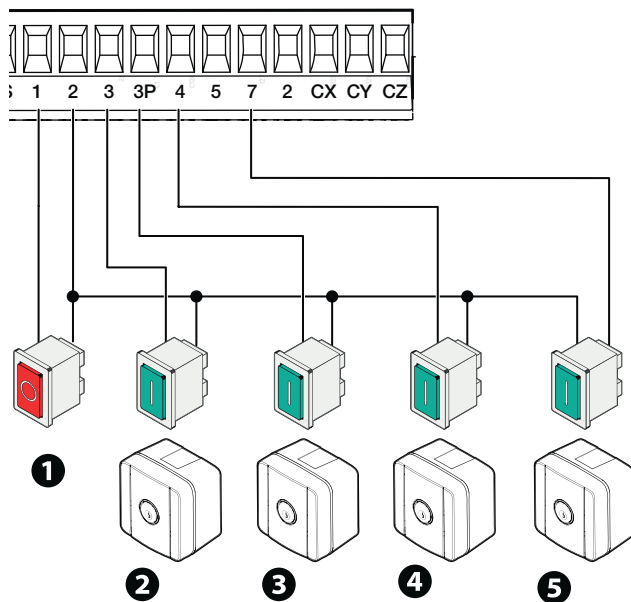

## Devices with BUS CXN system

The CXN CAME system is a two-wire non-polarised communication BUS which allows you to connect up all compatible CAME devices.

Connection to the BUS can be in a chain, star or mixed formation.

Once the system has been wired, and after having set the address on each device, the function of each accessory can be configured on the control panel. This method allows you to configure the set-up immediately without having to do so later and intervene directly on the accessories and system wiring.

The CXN BUS can support control devices, interfaces, photocells, safety devices, beacons and gateways at the same time.

### Cabling

- ❶ Chain connection
- ❷ Star connection
- ❸ Mixed connection

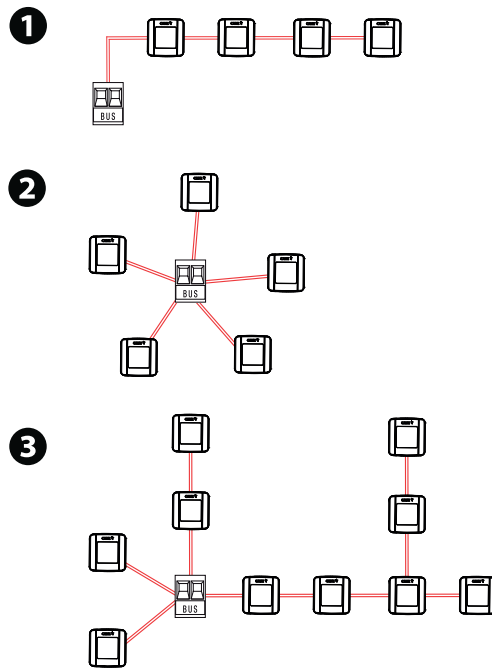

### Cable type

⚠ We recommend using a FROR 2x1mm<sup>2</sup> cable, maximum length from the control board: 50 m.

|                          |                       |
|--------------------------|-----------------------|
| Single branch length (m) | max. 50 m             |
| BUS cable                | 2 x 1 mm <sup>2</sup> |

📖 The total length of all branches can be a maximum of 150 m.

📖 The cable cannot be shielded.

### Maximum number of devices that can be connected, by type

| Type of device   | Maximum number of devices per type |
|------------------|------------------------------------|
| Selectors        | 7                                  |
| Photocell pairs  | 8                                  |
| Interfaces       | 2                                  |
| Flashing beacons | 2                                  |

### BUS CXN device consumption



Scan the QR code to access an interactive table showing consumption data, and calculate the maximum number of BUS devices you can connect to the control panel.

📖 BUS CXN device consumption is calculated in CXN units.

## Signalling devices

### 1 Additional light

It increases the light in the manoeuvring area.

### 2 Additional flashing beacon

It flashes when the operator opens and closes.

 See function [F18 - Additional light].

### 3 Operator status warning light

It notifies the user of the operator status.

 See function [F10 - Passage-open warning light].

### 4 LED strip and/or LED crown

If the red LEDs are flashing, the operator is moving.

If the green LEDs are on, the operator is open.

If the red LEDs are on, the operator is closed.

If the red LEDs are flashing quickly, the inspection hatch is open, the gearmotor is released or the boom has dropped away.

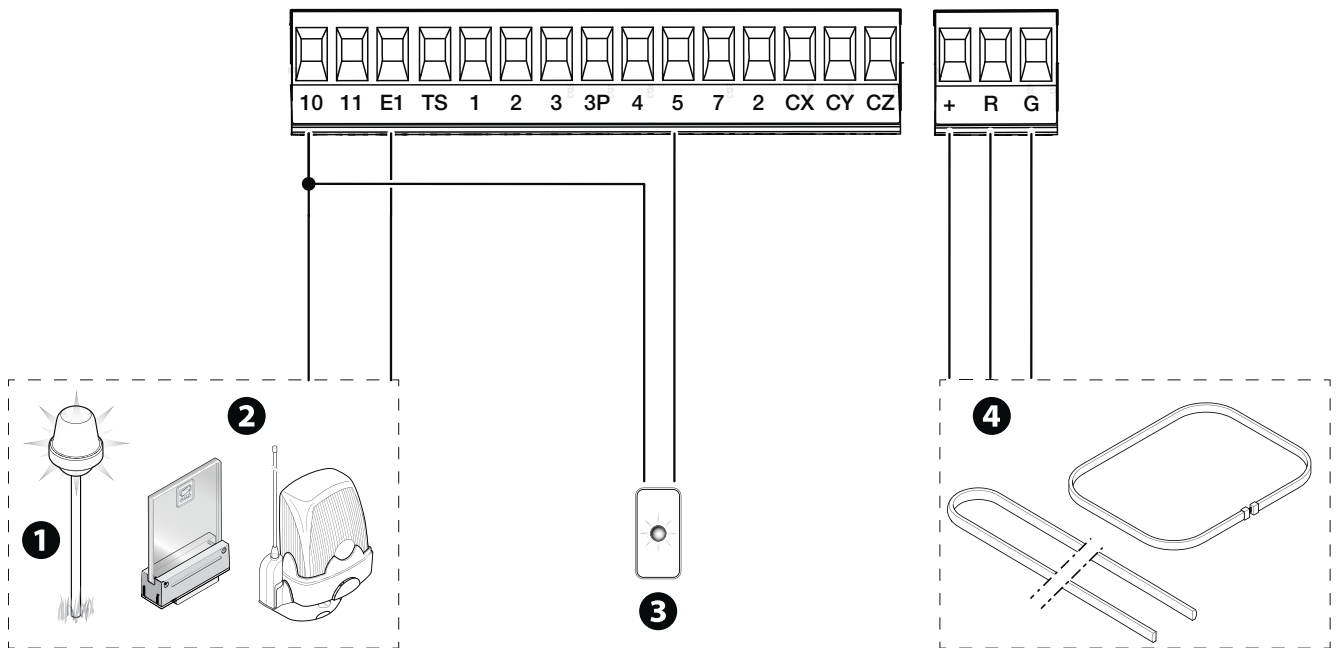

## Safety devices

Connect the safety devices to the CX, CY and/or CZ inputs (NC contacts).

During programming, configure the type of action that must be performed by the device connected to the input.

 If used, the contacts CX CY CZ must be configured during programming.

 For systems with multiple pairs of photocells, please see the manual for the relevant accessory.

### DELTA photocells

Standard connection

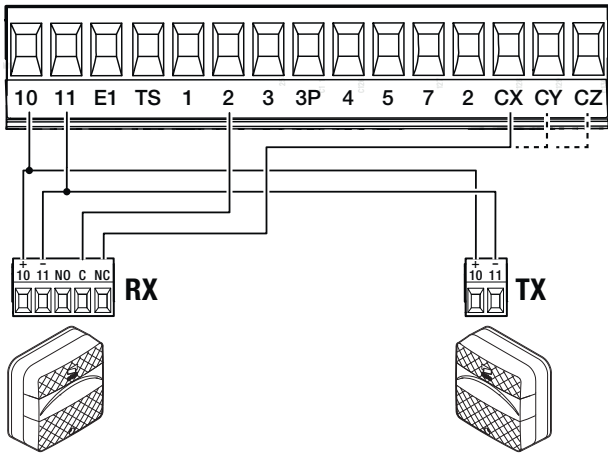

### DELTA photocells

Connection with safety test

 See function [F5] Safety devices test.

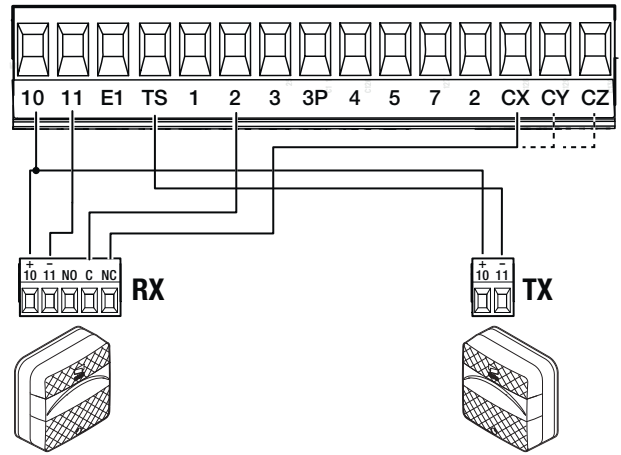

### DIR / DELTA-S photocells

Standard connection

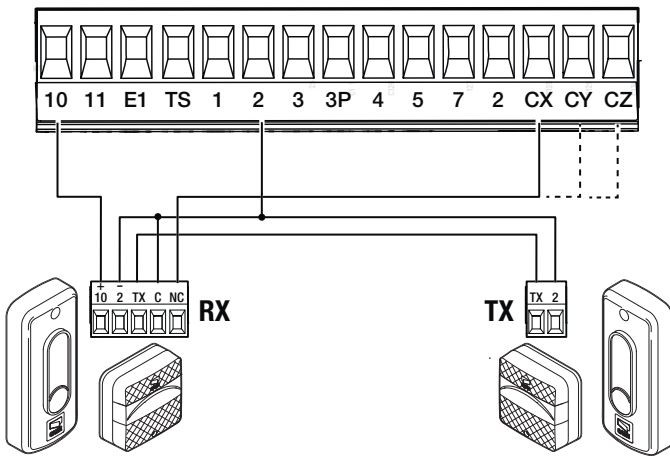

### DIR / DELTA-S photocells

Connection with safety test

 See function [F5] Safety devices test.

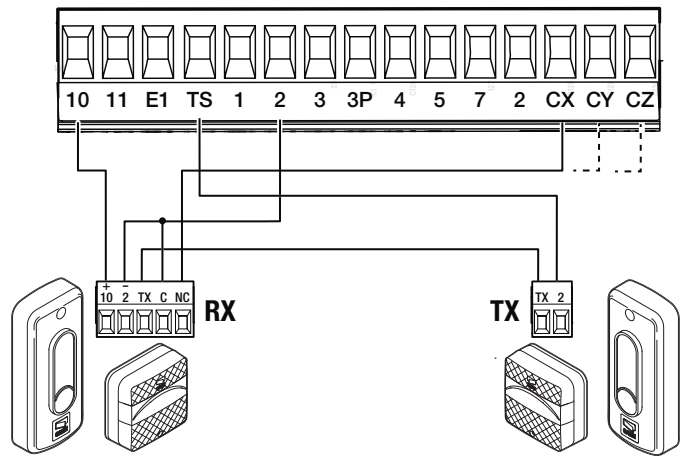

### DXR - DLX photocells

Standard connection

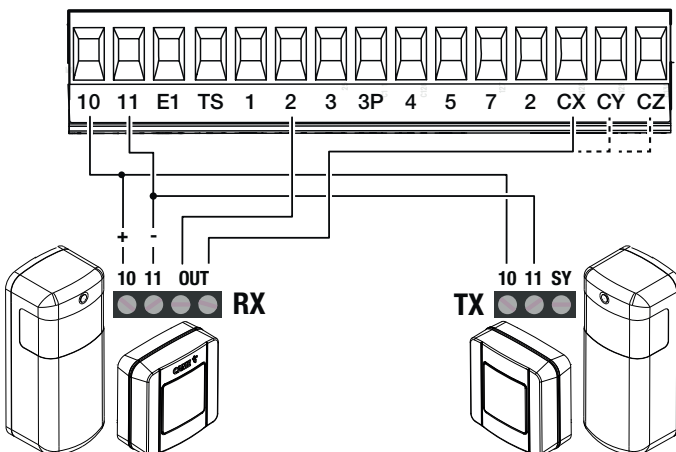

### DXR - DLX photocells

Connection with safety test

 See function [F5] Safety devices test.

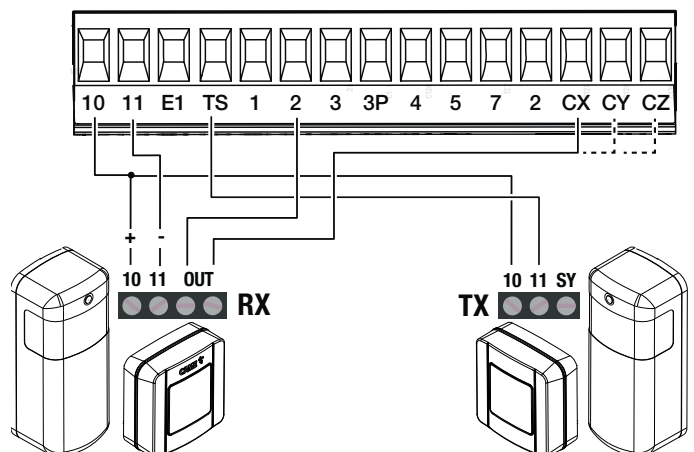

Programming button functions

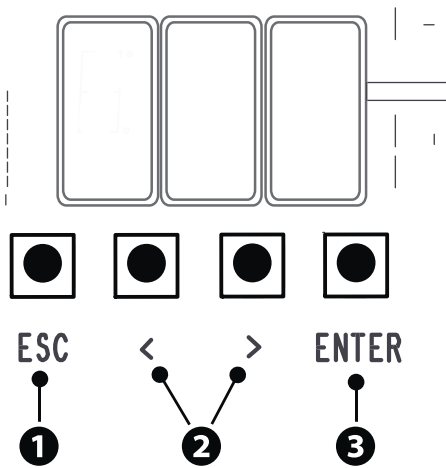

1 ESC button

The ESC button is used to perform the operations described below.  
 Exit the menu  
 Delete the changes  
 Go back to the previous screen

2 <> buttons

The <> buttons are used to perform the operations described below.  
 Navigate the menu  
 Increase or decrease values

3 ENTER button

The ENTER button is used to perform the operations described below.  
 Access menus  
 Confirm choice

📖 During movement, outside the menu, the ESC key stops the gate and the <> keys open and close the gate.

Getting started

📖 Once the electrical connections have been made, proceed with commissioning. Only skilled and qualified staff may perform this operation.  
 Check the warning and safety devices are working properly.  
 Make sure that there are no obstacles in the way.  
 Power up and proceed with the operations indicated below.

- A1 Boom length
- F54 Opening direction
- A2 Motor test
- A3 Travel calibration

📖 After powering up the system, the first manoeuvre is always to open the gate. Wait for the manoeuvre to be completed.  
 📖 Press the ESC button or STOP button immediately in the event of any faults, malfunctions, strange noises or vibrations, or unexpected behaviour in the system.  
 📖 If "A3" scrolls across the display, this means that the electronic board has not yet been calibrated.  
 At the end of commissioning, check the correct operation of the device using the buttons near the display. Check that the accessories also work correctly.

Functions menu

Total stop

This stops the boom and excludes automatic closing. Use a control device to resume movement.

|    |                     |
|----|---------------------|
| F1 | ON<br>OFF (Default) |
|----|---------------------|

CX input , CY input , CZ input

Associate a function with the input CX CY CZ

|    |   |
|----|---|
| F2 | OFF (Default)   |
| F3 | C1 = Reopen while closing (photo-cells)<br>C4 = Obstacle standby (photo-cells)  |
| F4 | C5 = Immediate closure at the travel end during opening<br>C7 = Reopen while closing (sensitive edges)<br>C9 = Immediate closure at the travel end during opening with obstacle standby during closure<br>C10 = Immediate closure during opening with obstacle standby during closure (NO contact)<br>C11 = Immediate closure during opening with obstacle standby during closure (NC contact)<br>C13 = Reopen while closing, with immediate closure once the obstruction has been removed, even if the boom is not in motion<br>r7 = Reopen while closing (sensitive edge with 8K2 resistor) |

## Safety devices test

Check that the photocells connected to the inputs are operating correctly, after each opening and closing command.

|           |  |
|-----------|--|
| <b>F5</b> | OFF (Default)<br>1 = CX<br>2 = CY<br>3 = CX+CY<br>4 = CZ<br>5 = CX+CZ<br>6 = CY+CZ<br>7 = CX+CY+CZ |
|-----------|--|

## Hold-to-run

With the function active, the operator stops moving (opening or closing) when the control device is released.

 When the function is active, it excludes all other control devices.

|           |                     |
|-----------|---------------------|
| <b>F6</b> | OFF (Default)<br>ON |
|-----------|---------------------|

## Obstacle with motor stopped

With the function active and the operator stopped, an open or close command is not performed if the safety devices detect an obstacle.

|           |                     |
|-----------|---------------------|
| <b>F9</b> | OFF (Default)<br>ON |
|-----------|---------------------|

## Passage-open warning light

Barrier status signal.

|            |   |
|------------|---|
| <b>F10</b> | 0 = Warning light on (default) - The light stays on when the boom is moving or open.<br>1 = Warning light flashing - The warning light flashes every half a second when the boom is opening and remains on when the boom is open. The light flashes every second when the boom is closing, and remains off when the boom is closed. |
|------------|---|

## Sensor type

Choose the type of access device.

|            |   |
|------------|---|
| <b>F14</b> | 1 = Keypad (Default)<br>0 = Transponder |
|------------|---|

## Electric lock

Choose the electric lock activation mode during boom manoeuvring.

|            |   |
|------------|---|
| <b>F17</b> | OFF (Default)<br>1 = The electric lock is deactivated during barrier opening and remains deactivated until the barrier is closed again. |
|------------|---|

## Additional light

Choose the operating mode for the lighting device connected to output E1.

|            |   |
|------------|---|
| <b>F18</b> | 0 =Flashing beacon (Default)<br>1 = Cycle light<br>The lamp stays on during the manoeuvre.<br> The light remains off if an automatic closing time is not set.<br>2 = Courtesy lamp<br>The light switches on when a manoeuvre starts and remains on once the manoeuvre has finished, for the time set under the function [F25 Courtesy time]. |
|------------|---|

## Automatic closure

Set the time before automatic closure is activated, once the opening travel end point has been reached.

 The function does not work if any of the safety devices are triggered when an obstacle is detected, or after a complete stop, or during a power outage.

|            |  |
|------------|--|
| <b>F19</b> | OFF (Default)<br>From 1 to 180 seconds |
|------------|--|

**Pre-flashing time**

Set the time for which the beacon is activated before each manoeuvre.

|            |                                  |
|------------|----------------------------------|
| <b>F21</b> | OFF (Default)<br>1 to 10 seconds |
|------------|----------------------------------|

**Courtesy time**

Set the lighting device operation time.

|            |   |
|------------|---|
| <b>F25</b> | 60 to 180 seconds (Default 180 seconds) |
|------------|---|

**Opening speed**

Set the opening speed (percentage of maximum speed).

 For booms complete with accessories (swing rest and/or skirt), reduce the speed.

|            |                           |
|------------|---------------------------|
| <b>F28</b> | 50% to 100% (Default 70%) |
|------------|---------------------------|

**Closing speed**

Set the closing speed (percentage of maximum speed).

 For booms complete with accessories (swing rest and/or skirt), reduce the speed.

|            |                                |
|------------|--------------------------------|
| <b>F29</b> | from 30% to 100% (Default 50%) |
|------------|--------------------------------|

**Travel sensitivity**

Adjust the obstruction detection sensitivity during the gate travel in percentage terms.

|            |  |
|------------|--|
| <b>F34</b> | 10% to 100% (Default 100%)<br>10% = minimum thrust and high obstruction sensitivity<br>100 % =maximum thrust and low obstruction sensitivity |
|------------|--|

**RSE communication**

Configure the function performed by the boards connected to the RSE1 and RSE2 connectors.

If an RSE card – configured for paired connections – is plugged into the RSE\_1 connector, use the RSE\_2 connector for remote connection (CRP). In this case, a CAME KEY cannot be connected.

|                            |   |            |            |            |                            |                            |                 |               |            |
|----------------------------|---|------------|------------|------------|----------------------------|----------------------------|-----------------|---------------|------------|
| <b>F49</b>                 | <table border="0"> <tr> <td><b>rE1</b></td> <td><b>rE2</b></td> </tr> <tr> <td>1 = Paired</td> <td>3 = CRP/CAME KEY (Default)</td> </tr> <tr> <td>3 = CRP/CAME KEY (Default)</td> <td>5 = I/O - RS485</td> </tr> <tr> <td>4 = Alternate</td> <td>6 = ModBus</td> </tr> </table> | <b>rE1</b> | <b>rE2</b> | 1 = Paired | 3 = CRP/CAME KEY (Default) | 3 = CRP/CAME KEY (Default) | 5 = I/O - RS485 | 4 = Alternate | 6 = ModBus |
| <b>rE1</b>                 | <b>rE2</b>  |            |            |            |                            |                            |                 |               |            |
| 1 = Paired                 | 3 = CRP/CAME KEY (Default)  |            |            |            |                            |                            |                 |               |            |
| 3 = CRP/CAME KEY (Default) | 5 = I/O - RS485   |            |            |            |                            |                            |                 |               |            |
| 4 = Alternate              | 6 = ModBus  |            |            |            |                            |                            |                 |               |            |

**Save data**

Save user data, timings and configurations to the memory device (memory roll or USB key).

 The function is displayed only when a USB stick is inserted into the USB port or a memory roll card is inserted into the control board.

|            |                                     |
|------------|-------------------------------------|
| <b>F50</b> | OFF (Default)<br>ON (Run operation) |
|------------|-------------------------------------|

**Read data**

Upload user data, timings and configurations from the memory device (memory roll or USB key).

 The function is displayed only when a USB stick is inserted into the USB port or a memory roll card is inserted into the control board.

|            |                                     |
|------------|-------------------------------------|
| <b>F51</b> | OFF (Default)<br>ON (Run operation) |
|------------|-------------------------------------|

**Transferring MASTER-SLAVE parameters**

Share parameters programmed on the Master barrier with the Slave barrier.

 This only appears if the F49 function is set to [Paired] or [Alternate].

|            |                     |
|------------|---------------------|
| <b>F52</b> | OFF (Default)<br>ON |
|------------|---------------------|

### Opening direction

Set the boom opening direction.

|            |   |
|------------|---|
| <b>F54</b> | 0 = To the left (default)<br>1 = To the right |
|------------|---|

### CRP address

Assign a unique identification code (CRP address) to the control board.

 The function is used where there are multiple operators connected to the same communication BUS using the CRP protocol.

|            |          |
|------------|----------|
| <b>F56</b> | 1 to 254 |
|------------|----------|

### Configure maintenance

Set the number of manoeuvres the operator can perform before a maintenance warning signal is generated.

 The warning is displayed as an [SEr] message and signalled by 3 + 3 flashes every hour on the device [Passage-open warning light].

|            |   |
|------------|---|
| <b>F58</b> | OFF (Default)<br>1 to 999 (1 = 1000 manoeuvres) |
|------------|---|

### Pre-flashing

Choose the type of manoeuvre that activates the flashing beacon in advance.

 Set how much earlier the flashing beacon is activated under the function [Pre-flashing time].

|            |  |
|------------|--|
| <b>F61</b> | 0 = when opening and closing (Default)<br>1 = only when closing<br>2 = only when opening |
|------------|--|

### RSE speed

Set the remote connection system communication speed on ports RSE1 and RSE2.

|            |                         |                         |
|------------|-------------------------|-------------------------|
| <b>F63</b> | <b>rE1</b>              | <b>rE2</b>              |
|            | 2 = 4800 bps            | 2 = 4800 bps            |
|            | 3 = 9600 bps            | 3 = 9600 bps            |
|            | 4 = 14400 bps           | 4 = 14400 bps           |
|            | 5 = 19200 bps           | 5 = 19200 bps           |
|            | 6 = 38400 bps (default) | 6 = 38400 bps (default) |
|            | 7 = 57600 bps           | 7 = 57600 bps           |
|            | 8 = 115200 bps          | 8 = 115200 bps          |

### FCA FCC warnings

Configure the method with which the FCA and FCC outputs report the boom status.

|            |   |
|------------|---|
| <b>F70</b> | OFF (Default)   |
|            | 1 = Impulse<br>When the boom reaches the travel end point (while opening or closing), the FCA-CM1 or FCC-CM2 contact closes for one second.   |
|            | 2 = Steady<br>When the boom reaches the travel end point (while opening or closing), the FCA-CM1 or FCC-CM2 contact closes and remains closed.  |
|            | 3 = Custom<br>The FCA-CM1 contact is closed with the boom in the open travel end position and during the opening manoeuvre. The FCC-CM2 contact is closed with the boom in the closed travel end position and during the closing manoeuvre. |
|            |   |

### Opening counter

With the function active, you can send a series of opening commands corresponding to the number of vehicles which have to be authorised to pass through the gate. The function can only be operated by control devices connected to the contact 2-3. The magnetic contact, to which the loop that counts vehicles in transit is connected, is connected to an input. This input must be programmed to operate in C5/C9/C10 mode. At the end of the count the passage is closed.

|            |                     |
|------------|---------------------|
| <b>F75</b> | OFF (Default)<br>ON |
|------------|---------------------|



## Emergency battery operation

Emergency function in the event of a power outage. Batteries required.

|            |   |
|------------|---|
| <b>F93</b> | OFF (Default)<br>1 = Immediate opening - In the event of a power outage, the operator runs an opening command within 1 minute and all other commands are blocked until power is restored. |
|------------|---|

## New user

Register up to a maximum of 250 users and assign a function to each one.

 The operation can be carried out by using a transmitter or a BUS selector device (e.g. a keypad or transponder reader). The boards that manage the control devices (AF - R700 - R800) must be inserted into the connectors.

|           |  |
|-----------|--|
| <b>U1</b> | 1 = Step-by-step - The first command is to open and the second to close.<br>2 = Sequential - The first command is to open, the second to STOP, the third to close and the fourth to STOP.<br>3 = Open<br>4 = Pedestrian/partial opening<br> When the barrier is in [Paired] mode, the [Partial Opening] command opens the Master barrier.<br>6 = BUS 1 module relay - Activate output 2 (relay output) on BUS 1 I/O module<br>7 = BUS 2 module relay - Activate output 2 (relay output) on BUS 2 I/O module<br><br>Choose the function to be assigned to the user.<br>Press ENTER to confirm.<br>The free position in the memory is shown intermittently for a maximum of 10 seconds. During this phase, send the code from the control device.<br>Repeat the procedure to add other users. |
|-----------|--|

## Remove user

Remove one of the registered users.

|           |   |
|-----------|---|
| <b>U2</b> | Use the arrows to change the status from OFF to ON and press ENTER to confirm.<br>Use the arrows to choose the number associated with the user you want to remove.<br>No. 1 > 250<br>Alternatively, the control device associated with the user you want to remove can be activated.<br>Press ENTER to confirm.<br> "CLR" will appear to confirm deletion. |
|-----------|---|

## Remove all

Remove all registered users.

|           |  |
|-----------|--|
| <b>U3</b> | OFF (Cancel operation)<br>On (Run operation) |
|-----------|--|

## Radio decoding

Choose the type of radio coding for the transmitters enabled to control the operator.

 If you choose the type of radio coding for the transmitters [Rolling code] or [TW key block], any transmitters with a different type of radio coding saved previously will be deleted.

|           |  |
|-----------|--|
| <b>U4</b> | 1 = All decoding (default)<br>2 = Rolling code<br>3 = TW key block |
|-----------|--|

## Self-Learning Rolling

Save a new rolling code transmitter by activating acquisition from a rolling code transmitter that has already been saved. The saving and acquisition procedures are explained in the transmitter manual.

|           |                     |
|-----------|---------------------|
| <b>U8</b> | OFF (Default)<br>ON |
|-----------|---------------------|

## Boom length

Set the boom length.

|           |  |
|-----------|--|
| <b>A1</b> | 3 = 3 m boom<br>4 = 4 m boom<br>5 = 5 m boom<br>6 = 6 m boom<br>8 = 8 m boom |
|-----------|--|

## Motor test

Check the boom opens in the correct direction.

 If the keys do not execute the commands correctly, invert the boom opening direction.

|           |   |
|-----------|---|
| <b>A2</b> | The button > makes the motor turn in clockwise direction.<br>The button < makes the motor turn in an anticlockwise direction. |
|-----------|---|

## Travel calibration

Start the travel self-learning.

|           |  |
|-----------|--|
| <b>A3</b> | OFF (Cancel operation)<br>ON (Run operation) |
|-----------|--|

## Parameter reset

Restore the factory configurations except for: [users], [boom length], [CRP address], [RSE2 settings], [password] and the settings related to the travel calibration.

|           |  |
|-----------|--|
| <b>A4</b> | OFF (Cancel operation)<br>ON (Run operation) |
|-----------|--|

## Manoeuvre counter

View the number of total or partial operator manoeuvres (after maintenance).

 The number of manoeuvres is the number shown multiplied by 1000.

|           |  |
|-----------|--|
| <b>A5</b> | Tot = total manoeuvres - Manoeuvres performed since the operator was installed.<br>Par = partial manoeuvres - Manoeuvres carried out after the last maintenance.<br> Under the [Par] parameter, press the ENTER key to reset the number of partial manoeuvres. [Clr] will appear on the screen to confirm deletion. |
|-----------|--|

## FW version

Display the firmware version number.

**H1**

## Enable password

Set a 3-digit password. The password will be requested to anyone who wants to access the main menu.

Remove the password that protects access to the main menu.

|           |   |   |
|-----------|---|---|
| <b>H3</b> | ON<br>Use the arrows and the Enter button to dial the desired code. | OFF<br>Press ENTER to confirm deletion. |
|-----------|---|---|

## Forgotten password

If you lose the password, you will need to reset the board to its factory settings. See [Factory reset].

## Factory reset

To restore the electronic board data to factory settings:

Disconnect the control board from the power supply.

Press and hold the < and > buttons, then reconnect the control board to the power supply.

Continue to press and hold the < > buttons until [ON/OFF] is displayed.

Select [ON].

Press ENTER to confirm.

 When you reset the control board, all saved users, set times and calibration operations are deleted.

## BUS device status

Show the status of all devices that can be connected to the BUS and managed by the firmware in use.

### Key

b = BUS photocells  
 d = BUS selector  
 L = BUS flashing beacon  
 i = I/O BUS module  
 <n> is the device number.  
 <x> is the device status.

### <x> device status

ll = Conflicting address  
 o = Working  
 c = Working with alarm signal  
 F = Device fault  
 - = No communication or not present

|                  |  |
|------------------|--|
| <p><b>H4</b></p> | <p>b&lt;n&gt;.&lt;x&gt;<br/>  &lt;n&gt; goes from 1 to 8 [Function B1 - B8].</p> <p>d&lt;n&gt;.&lt;x&gt;<br/>  &lt;n&gt; goes from 1 to 7 [Function b21 - b27].</p> <p>L&lt;n&gt;.&lt;x&gt;<br/>  &lt;n&gt; from 1 to 2</p> <p>i&lt;n&gt;.&lt;x&gt;<br/>  &lt;n&gt; goes from 1 to 2 [Function b11 - b12].</p> |
|------------------|--|

## BUS photocells

Associate a function with the input for the BUS photocells.

- [b1] corresponds to the pair of photocells 1, as set on the photocell DIP switch.
- [b8] corresponds to the pair of photocells 8, as set on the photocell DIP switch.
- The function only appears if there is a BUS photocell connected.

|   |  |
|---|--|
| <p><b>b1</b></p> <p><b>b2</b></p> <p><b>b3</b></p> <p><b>b4</b></p> <p><b>b5</b></p> <p><b>b6</b></p> <p><b>b7</b></p> <p><b>b8</b></p> | <p>OFF (Default)<br/>                 C1 = Reopen while closing (photocells)<br/>                 C4 = Obstacle standby (photocells)<br/>                 C5 = Immediate closure at the travel end during opening<br/>                 C9 = Immediate closure at the travel end during opening with obstacle standby during closure<br/>                 C10 = Immediate closure during opening with obstacle standby during closure<br/>                 C13 = Reopen while closing, with immediate closure once the obstruction has been removed, even if the boom is not in motion<br/>                 C23 = Open command<br/>                 C24 = Close command</p> |
|---|--|

## I/O BUS module - Inputs

Associate a function with the I/O module inputs.

- [b11] corresponds to the I/O module 1, as set on the device DIP switch.
- [b12] corresponds to the I/O module 2, as set on the device DIP switch.
- The function only appears if there is a BUS I/O module connected.

|                                     |                                   |  |
|-------------------------------------|-----------------------------------|--|
| <p><b>b11</b></p> <p><b>b12</b></p> | <p><b>l1</b></p> <p><b>l2</b></p> | <p>OFF (Default)<br/>                 C0 = This stops the operator and excludes automatic closing. Use a control device to resume movement.<br/>  If it is activated, the input is used as a normally closed contact.<br/>                 r7 = Reopen while closing (sensitive edge with 8K2 resistor).<br/>                 C22 = Partial opening<br/>                 C23 = Open<br/>                 C24 = Close<br/>                 C27 = Step-by-step - The first command is to open and the second to close.</p> |
|-------------------------------------|-----------------------------------|--|

### I/O BUS module - Light output

Associate a function with output 1 on the I/O modules.

 [b11] corresponds to the I/O module 1, as set on the device DIP switch.

 [b12] corresponds to the I/O module 2, as set on the device DIP switch.

 The function only appears if there is a BUS I/O module connected.

|            |           |  |
|------------|-----------|--|
| <b>b11</b> | <b>o1</b> | 0 = Passage-open warning light - It notifies the user of the operator status [F10 - Passage-open warn. light].<br>1 = Cycle light - The lamp stays on during the manoeuvre.<br>2 = Courtesy light - The light switches on when a manoeuvre starts and remains on once the manoeuvre has finished, for the time set under the function [F25 - Courtesy time]. |
| <b>b12</b> |           |  |

### I/O BUS module - Relay output

Associate a function with output 2 on the I/O modules.

 [b11] corresponds to the I/O module 1, as set on the device DIP switch.

 [b12] corresponds to the I/O module 2, as set on the device DIP switch.

 The function only appears if there is a BUS I/O module connected.

|            |           |  |
|------------|-----------|--|
| <b>b11</b> | <b>o2</b> | 0 = Bistable<br>ON - from 1 to 180 seconds (Default 1) |
| <b>b12</b> |           |  |

### BUS key selector

Associate a function with the BUS key selector inputs. Different functions can be set according to the key turning direction.

 [b21] corresponds to selector 1, as set on the device DIP switch.

 [b27] corresponds to selector 7, as set on the device DIP switch.

 The function only appears if there is a BUS key selector connected.

|            |                               |   |
|------------|-------------------------------|---|
| <b>b21</b> | <b>riG</b> = Key to the right | Choose the command to associate with the key movement.  |
| <b>b22</b> | <b>LEF</b> = Key to the left  | 0 = Step-by-step - The first command is to open and the second to close.<br>1 = Sequential - The first command is to open, the second to STOP, the third to close and the fourth to STOP.<br>2 = Open<br>3 = Close<br>4 = Partial opening<br>5 = Stop<br>7 = BUS 1 module relay - Activate output 2 (relay output) on BUS 1 I/O module<br>8 = BUS 2 module relay - Activate output 2 (relay output) on BUS 2 I/O module |
| <b>b23</b> |                               |   |
| <b>b24</b> |                               |   |
| <b>b25</b> |                               |   |
| <b>b26</b> |                               |   |
| <b>b27</b> |                               |   |

### BUS flashing beacon <Automatic closing time colour>

Set the BUS flashing beacon colour during the automatic closing time.

 The function only appears if there is a BUS flashing beacon connected.

|            |           |  |
|------------|-----------|--|
| <b>b40</b> | <b>L1</b> | OFF<br>1 = White<br>2 = Yellow<br>3 = Orange<br>4 = Red<br>5 = Purple<br>6 = Blue<br>7 = Light blue<br>8 = Green (Default) |
|------------|-----------|--|

**<Opening colour> BUS flashing beacon**

Set the BUS flashing beacon colour during operator opening.

 The function only appears if there is a BUS flashing beacon connected.

|            |           |   |
|------------|-----------|---|
| <b>b40</b> | <b>L2</b> | 1 = White<br>2 = Yellow<br>3 = Orange<br>4 = Red (Default)<br>5 = Purple<br>6 = Blue<br>7 = Light blue<br>8 = Green |
|------------|-----------|---|

**<Closing colour> BUS flashing beacon**

Set the BUS flashing beacon colour during operator closing.

 The function only appears if there is a BUS flashing beacon connected.

|            |           |   |
|------------|-----------|---|
| <b>b40</b> | <b>L3</b> | 1 = White<br>2 = Yellow<br>3 = Orange<br>4 = Red (Default)<br>5 = Purple<br>6 = Blue<br>7 = Light blue<br>8 = Green |
|------------|-----------|---|

**<Pre-flashing colour> BUS flashing beacon**

On the BUS flashing beacon, set the flash colour for before opening and closing manoeuvres (pre-flash).

 The function only appears if there is a BUS flashing beacon connected.

|                 |           |   |
|-----------------|-----------|---|
| <b>b40 &gt;</b> | <b>L4</b> | 1 = White (Default)<br>2 = Yellow<br>3 = Orange<br>4 = Red<br>5 = Purple<br>6 = Blue<br>7 = Light blue<br>8 = Green |
|-----------------|-----------|---|

**<Signal error> BUS flashing beacon**

Set the colour of the BUS flashing beacon in the event of an error signal.

 The warning light is activated after sending a command for movement.

 The function only appears if there is a BUS flashing beacon connected.

|                 |           |  |
|-----------------|-----------|--|
| <b>b40 &gt;</b> | <b>L5</b> | OFF (Default)<br>1 = White<br>2 = Yellow<br>3 = Orange<br>4 = Red<br>5 = Purple<br>6 = Blue<br>7 = Light blue<br>8 = Green |
|-----------------|-----------|--|

## Signal maintenance

Set the colour of the flash on enabled BUS devices (flashing beacons and selectors) when maintenance is necessary. With the function activated, these devices will signal that maintenance needs to be carried out at the start of each manoeuvre.

 Configure maintenance and set the number of manoeuvres. See the function [F58 - Configure maintenance].

 The function only appears if there is a BUS flashing beacon or a BUS selector connected.

|            |                |
|------------|----------------|
| <b>b43</b> | OFF (Default)  |
|            | 1 = White      |
|            | 2 = Yellow     |
|            | 3 = Orange     |
|            | 4 = Red        |
|            | 5 = Purple     |
|            | 6 = Blue       |
|            | 7 = Light blue |
|            | 8 = Green      |

**⚠ When using a GAME KEY device, always update the board firmware to the latest version.**

## Import/export data

**1** Insert the MEMORY ROLL card into the corresponding connector on the control board.

**2** Press the "Enter" button to access programming.

**3** Use the arrows to choose the desired function.

 The functions are displayed only when a MEMORY ROLL card is inserted.

### [F50] - Save data

Save user data, timings and configurations to the memory device (memory roll or USB key).

### [F50] - Read data

Upload user data, timings and configurations from the memory device (memory roll or USB key).

**⚠ Before inserting and removing the MEMORY ROLL card, DISCONNECT THE MAINS POWER SUPPLY TO THE LINE.**

 Remove the MEMORY ROLL card after the data has been loaded.

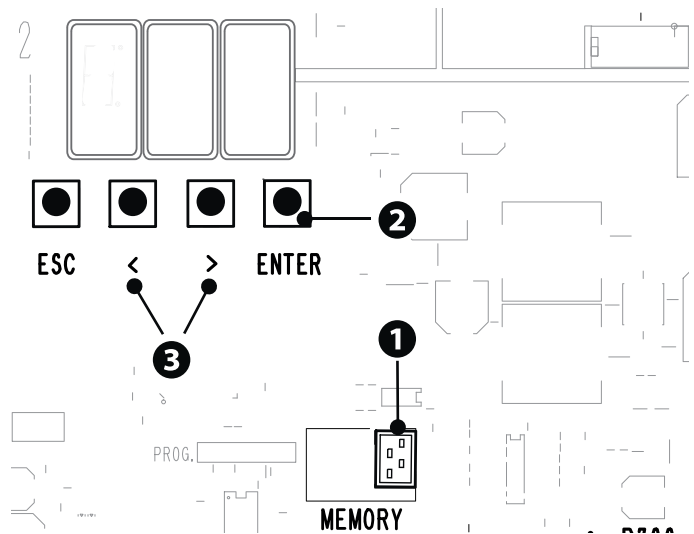

## FINAL OPERATIONS

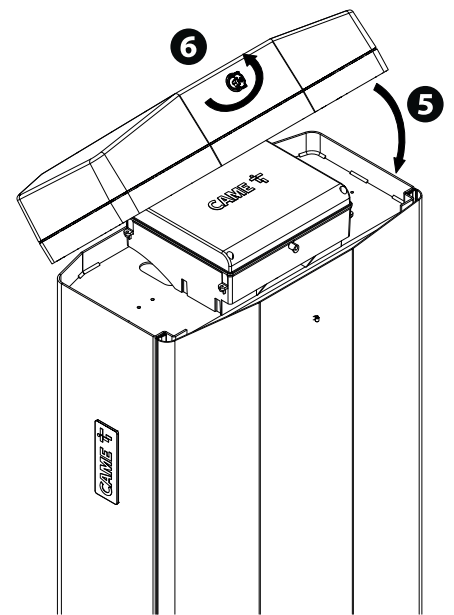
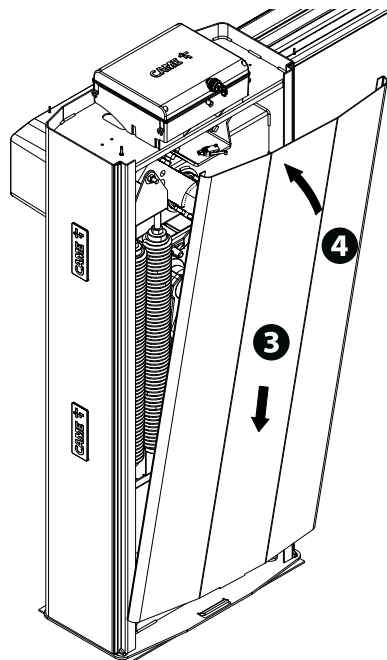
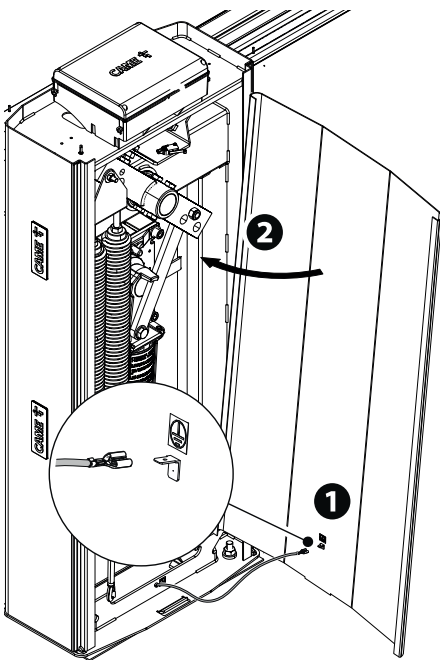

## PAIRED OPERATION

Two connected operators are controlled with one command.

### Electrical connections

Connect the two electronic boards with a UTP CAT 5 cable.

Fit an RSE card on both control boards, using the RSE\_1 connector.

Connect up the electrics for the devices and accessories.

 For information on connecting the electrics for the devices and accessories, please see the “ELECTRICAL CONNECTIONS” section.

 The devices and accessories must be connected to the control board which will be set as the MASTER.

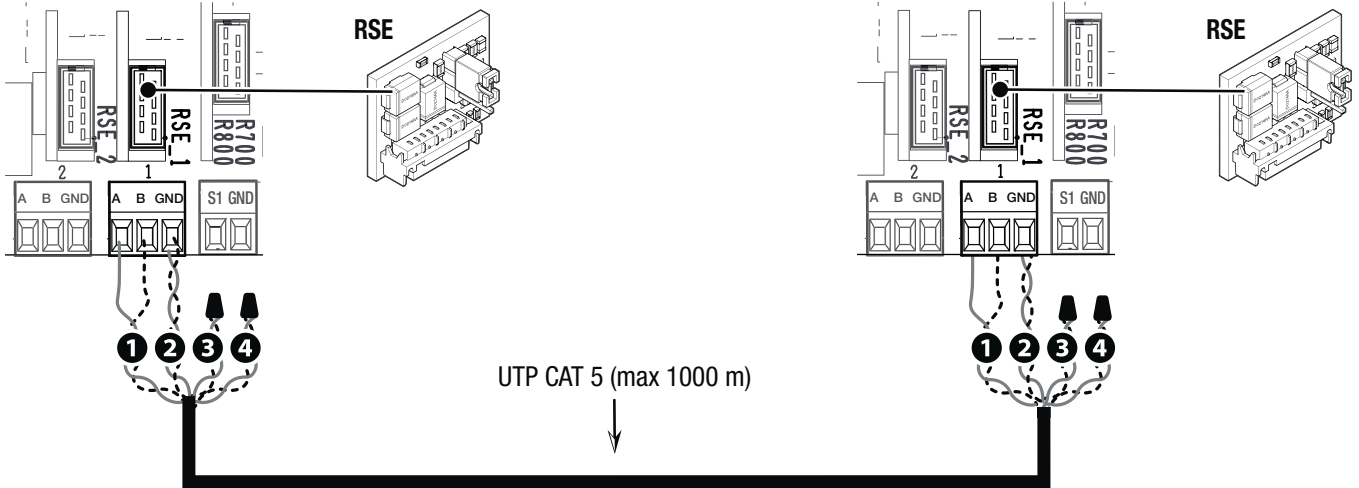

### Programming

 All programming operations described below must be performed only on the control board set as the MASTER.

Configure the RSE\_1 port in [Paired].

Enable the sharing of parameters programmed on the Master barrier with the Slave barrier.

 After programming the MASTER operator in [Paired], the second operator automatically becomes SLAVE.

### Saving users

 All save user operations must be performed only on the control board set as the MASTER.

 For user storage operations, see the [New user] function.

### Operating modes

**1** OPEN-CLOSE command (2-7), OPEN ONLY (2-3) or CLOSE ONLY (2-4)

**2** PARTIAL OPENING command (2-3P)

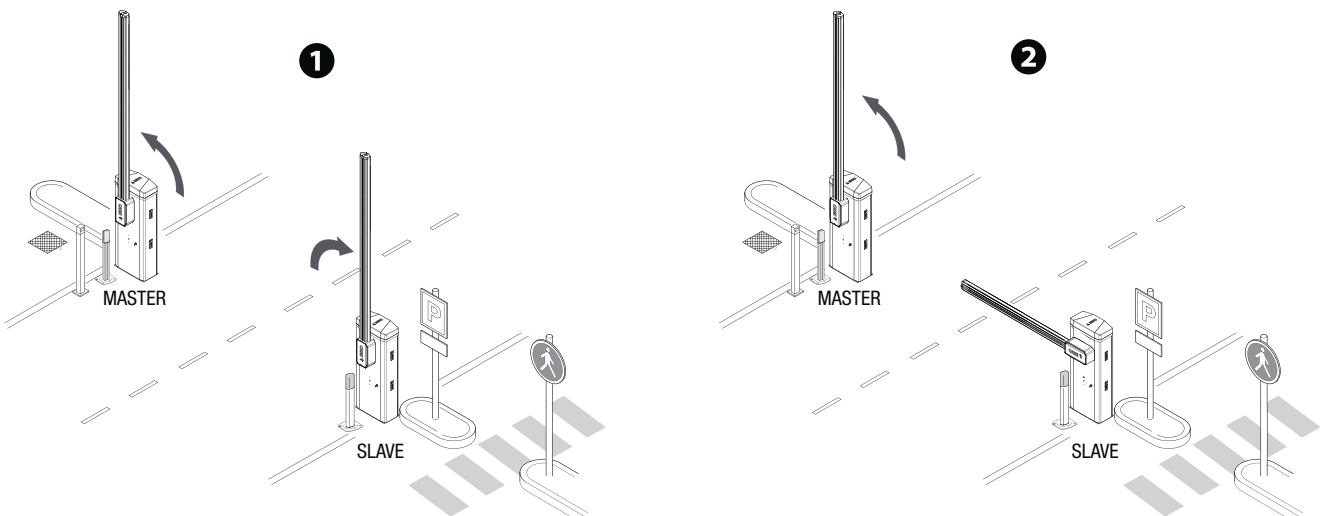

## ALTERNATE OPERATION

The first barrier opens, the vehicle passes, the first barrier closes, the second barrier opens, the vehicle passes and the second barrier closes.

### Electrical connections

Connect the two electronic boards with a UTP CAT 5 cable.

Fit an RSE card on both control boards, using the RSE\_1 connector.

Connect up the electrics for the devices and accessories.

 For information on connecting the electrics for the devices and accessories, please see the "ELECTRICAL CONNECTIONS" section.

 The control and safety devices must be connected on both electronic boards.

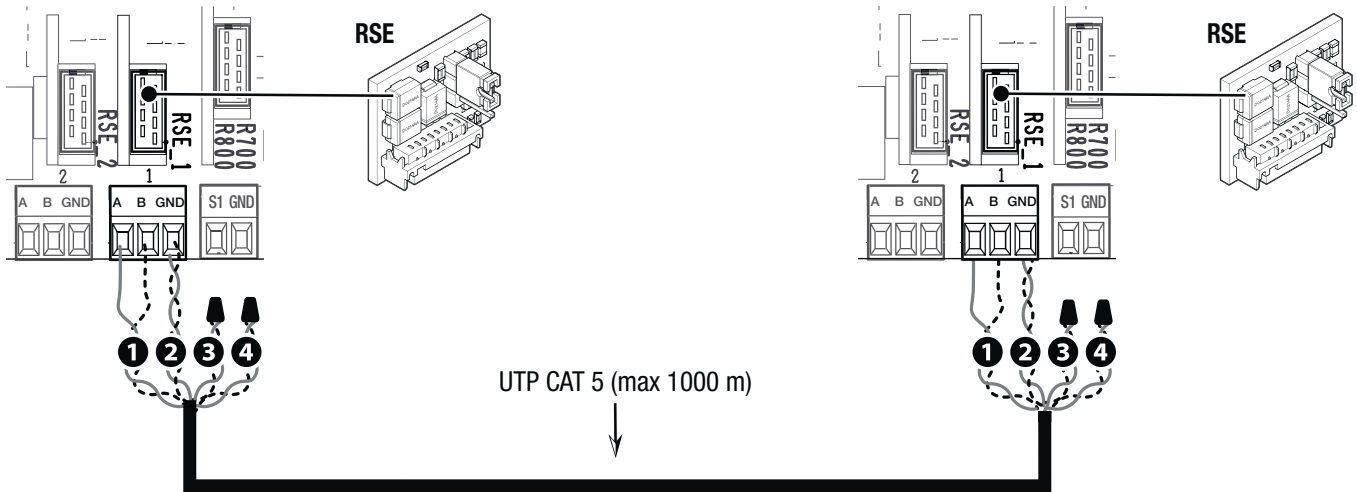

### Programming

On one of the two barriers, configure the [RSE\_1] function in [Alternate].

It activates the function [Automatic close] on both control boards.

### Saving users

 For user storage operations, see the [New user] function.

 When programming users, do not use the 2-3P OPEN ONLY command.

### Operating modes

**1** ONLY OPEN command (2-3) on barrier A

**1**

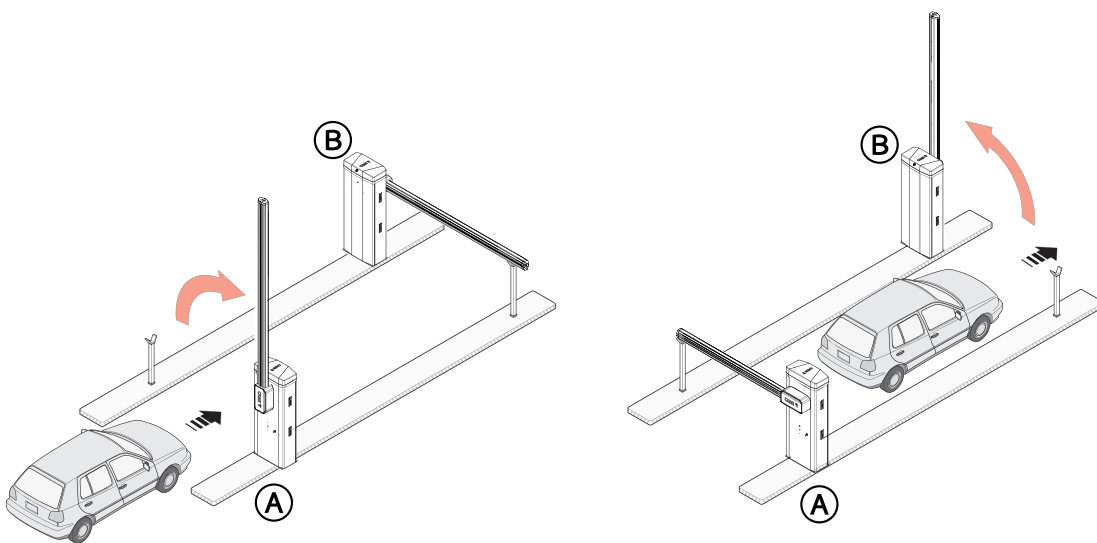



2 ONLY OPEN command (2-3) on barrier B

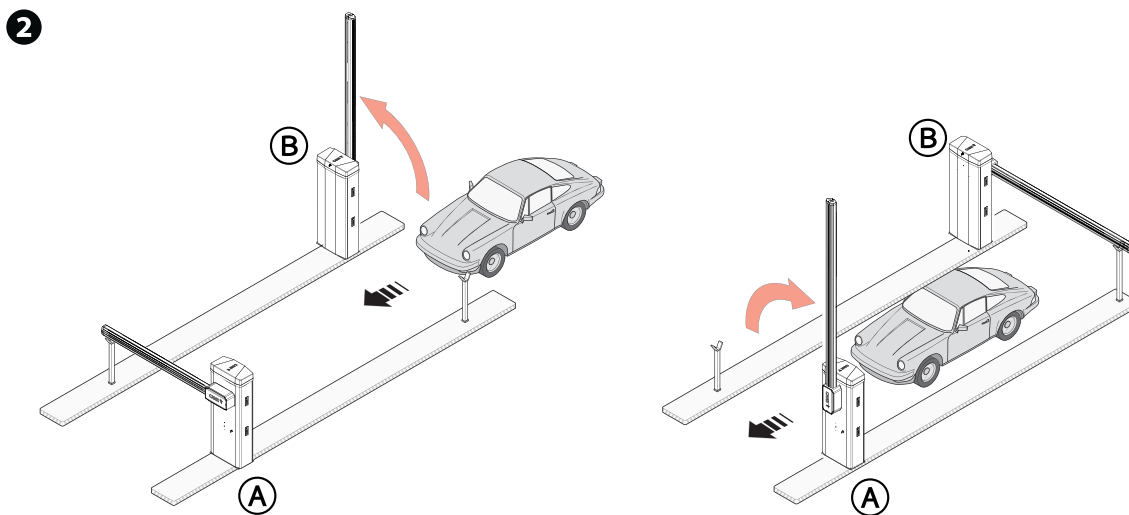

3 OPEN-CLOSE command (2-7) on barrier A or B for emergency opening

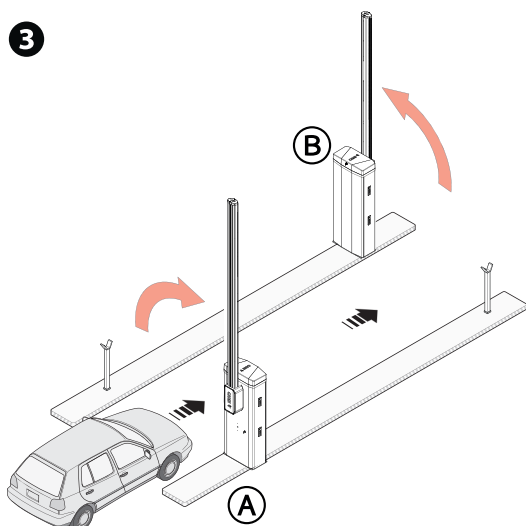

## MCBF

| Models                   | GT        |
|--------------------------|-----------|
| Standard boom L = 6.35 m | 3.000.000 |
| Skirt                    | -20%      |
| Mobile foot              | -20%      |
| Modular boom             | -20%      |
| Full-height skirt        | -30%      |

 The MCBF value relates to the barrier only and does not refer to any applicable accessories.

 The GARD GT barrier has been designed to perform up to 3 million cycles. Thanks to its 24V DC motor, it is extremely reliable and requires very little maintenance.

 The percentages indicate how much the number of cycles should be reduced in relation to the type and number of accessories installed.

 Before carrying out any cleaning or maintenance, or replacing any parts, disconnect the device from the power supply.

 This document informs the installer of the checks that must be carried out during maintenance.

 If the barrier is not used for long periods of time, e.g. for installations at sites with seasonal closures, release the spring and remove the boom.

 For information on correct installation and adjustments, please see the product installation manual.

 For information on choosing products and accessories, please see our product catalogue.

 If the barrier with an articulated joint is used, check that the moving parts of the joint are in good condition. Replace them if necessary.

Every 250,000 cycles and, in any case, every 6 months of operation, you must perform the maintenance work indicated below.

Perform a general and complete check of the tightness of the nuts and bolts.

Lubricate the spring when it is fully extended.

Check the 45° boom balance and if necessary tension the balance spring, adjusting its traction operating on the hooking tie rods.

Grease all of the moving mechanical parts.

Check the warning and safety devices are working properly.

Check that the microswitch connected to the cabinet hatch is working correctly.

Check the microswitch connected to the manual release is working properly, and the microswitch connected to the release accessories (optional).

Check for any wear on the moving mechanical parts and check that they are working properly.

Check the cables are intact and connected correctly.

 With boom L = 6.35 m complete with full-height skirt, replace the balance springs every 250,000 cycles or every 24 months of activity.

 With boom L = 7 m complete with single skirt, replace the balance springs every 250,000 cycles or every 24 months of activity.

Every 500,000 cycles and, in any case, every 24 months of operation, you must perform the maintenance work indicated below.

Replace the balance springs.

**ERROR MESSAGES**

|            |  |
|------------|--|
| <b>E2</b>  | Adjustment error   |
| <b>E3</b>  | Encoder failure error  |
| <b>E4</b>  | Service test failure error   |
| <b>E7</b>  | Operating time error   |
| <b>E8</b>  | Open release-hatch error   |
| <b>E9</b>  | Obstacle detected during closing   |
| <b>E10</b> | Obstacle detected during opening   |
| <b>E12</b> | Main power supply missing  |
| <b>E11</b> | The maximum number of obstacles detected consecutively has been exceeded |
| <b>E14</b> | Serial communication error   |
| <b>E15</b> | Incompatible transmitter error   |
| <b>E16</b> | Open SLAVE-motor hatch error   |
| <b>E24</b> | Communication error or malfunction of a BUS safety device                |
| <b>E25</b> | Conflicting addresses for configured BUS devices                         |

**NOTICES**

|            |                                       |
|------------|---------------------------------------|
| <b>C0</b>  | Wire contact 1-2 (NC) is open.        |
| <b>i3</b>  | The wire contact 2-3 (NO) is closed.  |
| <b>i3P</b> | The wire contact 2-3P (NO) is closed. |
| <b>i4</b>  | The wire contact 2-4 (NO) is closed.  |
| <b>i7</b>  | The wire contact 2-7 (NO) is closed.  |



**CAME** 

**CAME.COM**

**CAME S.P.A.**

Via Martiri della Libertà, 15  
31030 Dosson di Casier  
Treviso – Italy  
Tel. (+39) 0422 4940  
Fax (+39) 0422 4941